

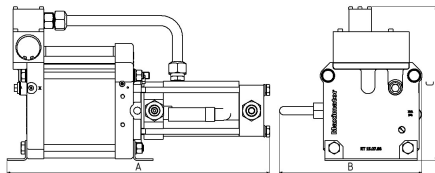

Technical Data Sheet

Liquefied Gas Pump

GLGP 5-5-NBR

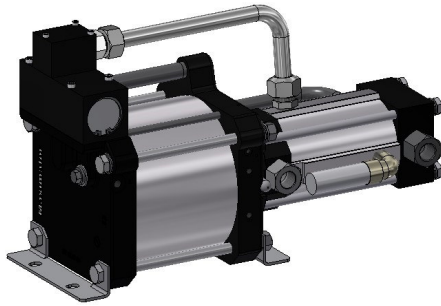

Technical Data:

Air drive pressure:	1 - 10 bar / 14.5 - 145 psi
Min. inlet pressure pA:	-0.9 bar / -13.1 psi
Max. outlet pressure pB:	90 bar / 1035 psi
Pressure ratio:	1:5.2 / 1:5.6
Displacement volume/double stroke:	373 cm ³ / 22.76 cu.inch

Connections:

Inlet:	1/2" BSP
Outlet:	1/2" BSP
Air drive:	3/4" BSP
Maximum operating temperature:	-20 °C - +60 °C
Net weight:	15.4 kg

Pressure and flow performances, please see enclosed graph.

Wetted materials of construction:

Seal package:	PTFE, NBR
Compressor head:	3.1645
Cylinder:	3.3206
Piston:	1.4542
Fittings:	1.4305 / 1.4404
Balls	1.4034
Springs	1.4310

Approximate Dimensions:

A:	466 mm
B:	253 mm
C:	272 mm

Available Options:

RS	Reduced Stroke
FS - Flame arrester	This option cannot be retrofitted and must be specified when ordering.
FEC:	For extreme Cycling
LT:	Low Temperature
LTA:	Low Temperature Ambient
Special sealing materials on request	

Please consult factory for more information. All technical and dimensional information subject to change. All General Terms and Conditions of sale, including limitations of our liability, apply to all products and services sold.



Leistungsdiagramm/Performance Graph GLGP 5-5

Prüfflüssigkeit/Test fluid: Wasser-Öl-Emulsion/Water Oil Emulsion ca. 1 - 10 cst

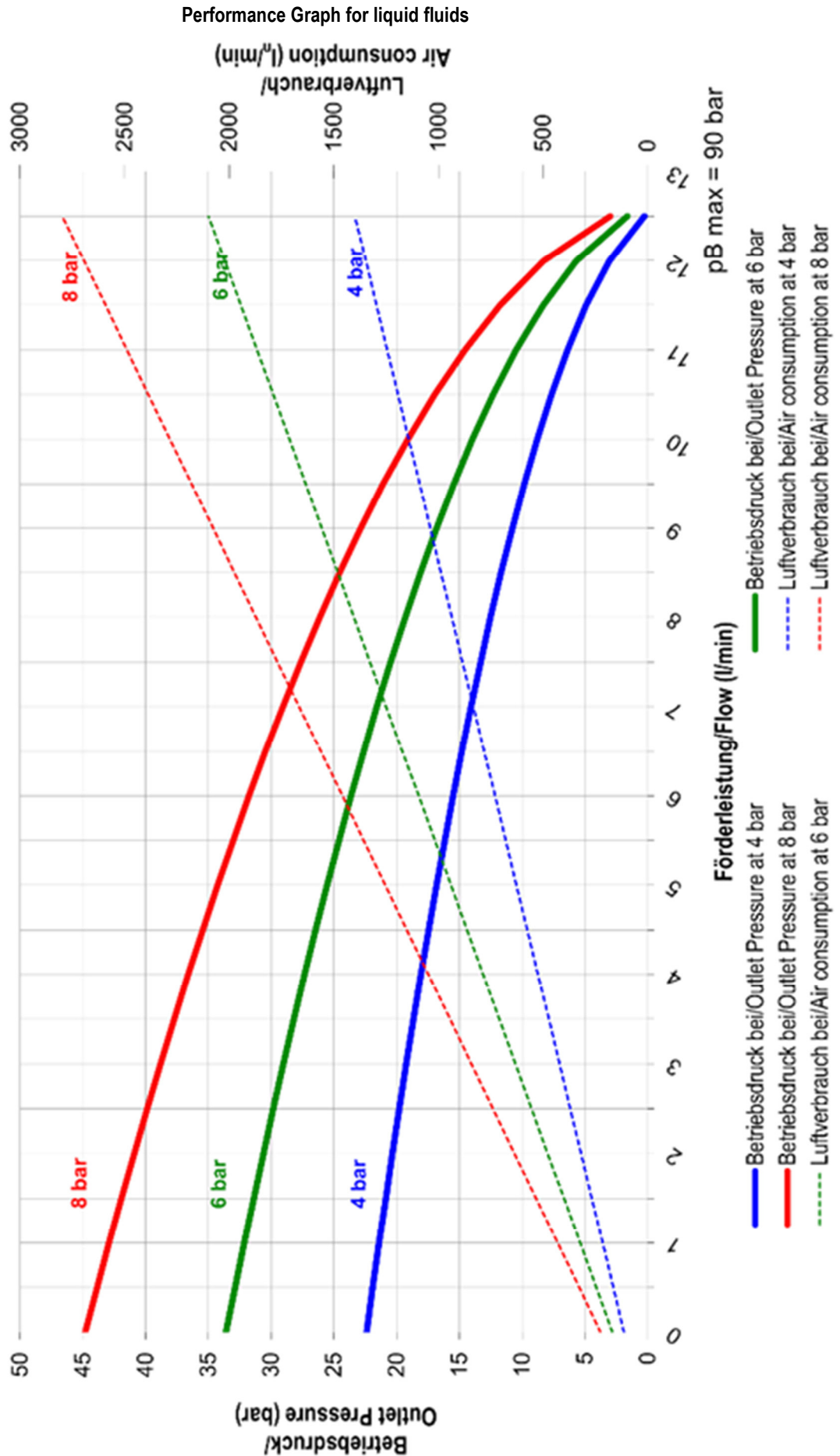



Performance Graph for gaseous fluids

Leistungsdiagramm/Performance Graph GLGP 5-5
Antriebsdruck/Drive pressure 4 bar
 Prüffluid/Test fluid: Stickstoff/Nitrogen

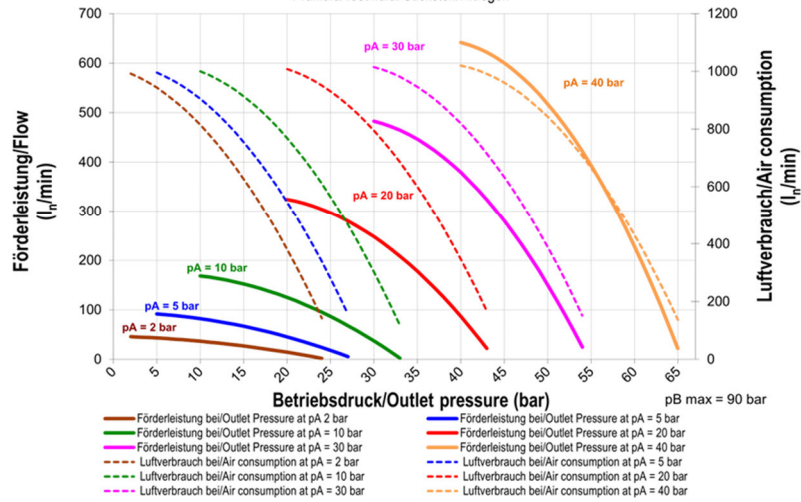

Leistungsdiagramm/Performance Graph GLGP 5-5
Antriebsdruck/Drive pressure 6 bar
 Prüffluid/Test fluid: Stickstoff/Nitrogen

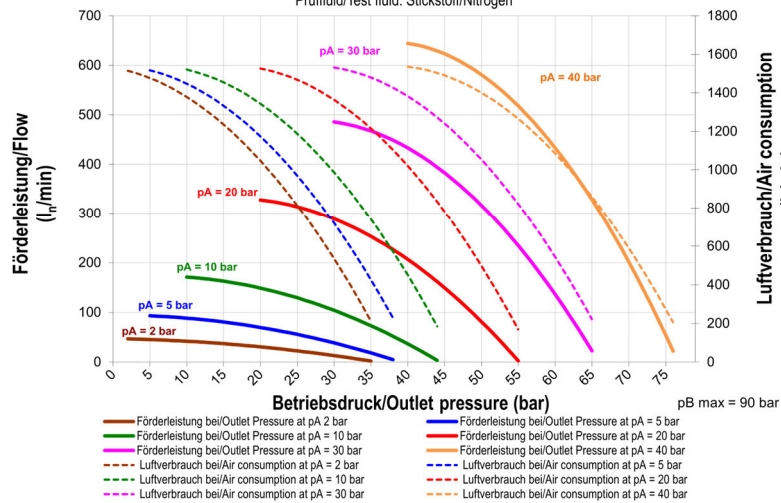

Leistungsdiagramm/Performance Graph GLGP 5-5
Antriebsdruck/Drive pressure 8 bar
 Prüffluid/Test fluid: Stickstoff/Nitrogen

