

# MAXIMATOR®

## Maximum Pressure.

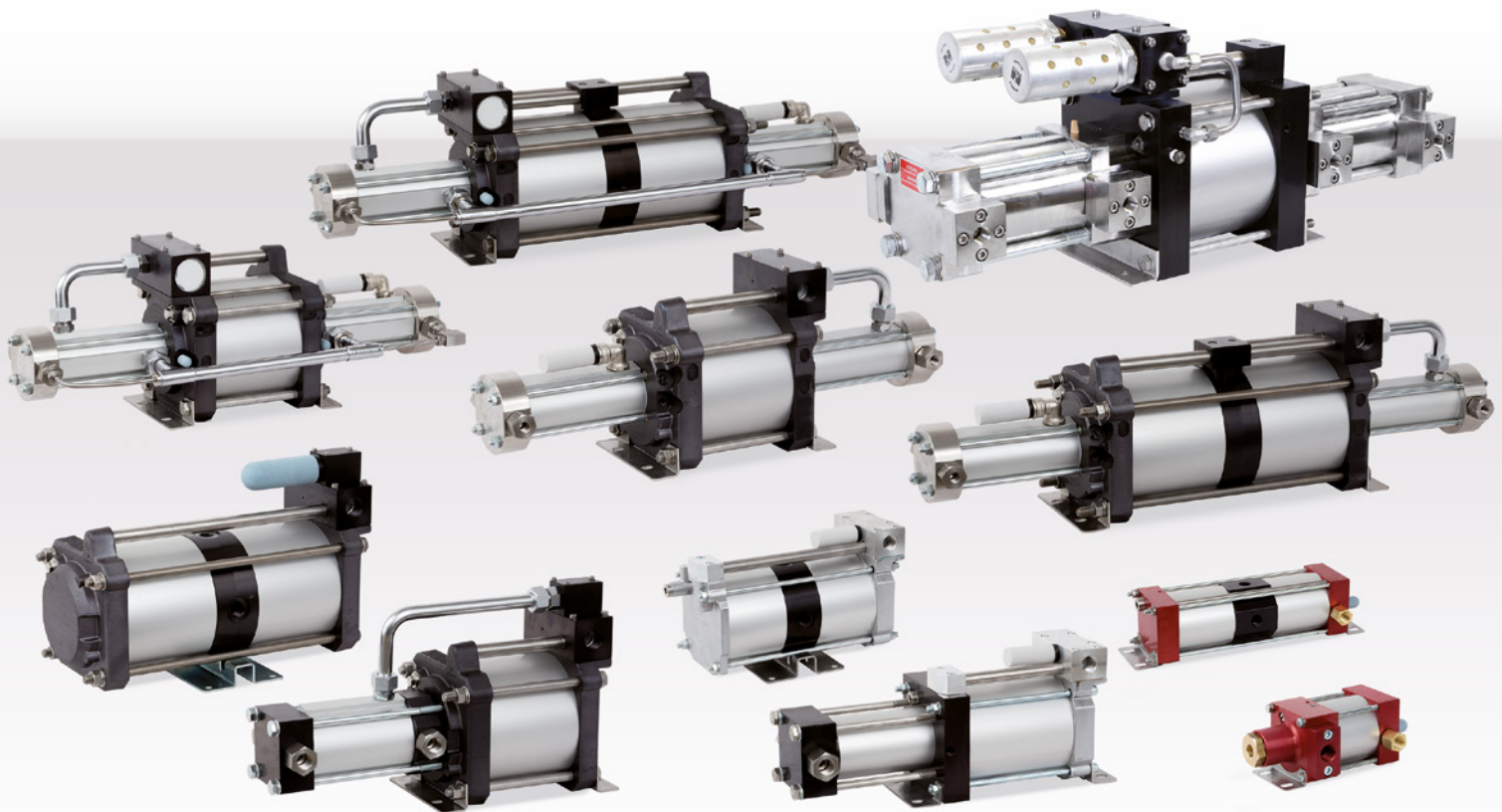

High Pressure Technology • Testing Equipment  
Hydraulics • Pneumatics



» Air driven high pressure gas boosters  
up to 2,400 bar (36,000 psi)

# » Content

Content	Page
Maximator worldwide - At your side, everywhere	3
<b>Gas booster Type DLE</b>	
Concept, Gas booster in detail, function and operation	4
Product range overview	5
Type coding	6
General information for gas booster operation	7
Fields of application	10
» DLE - single stage, single acting, 1 air drive section	12
» DLE - single stage, single acting, 2 air drive sections	14
» DLE - single stage, double acting, 1 air drive section	16
» DLE - single stage, double acting, 2 air drive sections	18
» DLE - two stage, 1 air drive section	20
» DLE - two stage, 2 air drive sections	22
» DLE - two stage, 3 air drive sections	24
» 8DLE - 8"-drive, single stage, double/quadruple acting, 1 or 2 air drive sections	26
Flow capacity	28
Gas booster selection	29
Overview of technical features and connections	30
Process fluids	31
<b>Compact-Booster Series</b>	32
<b>Additional products</b>	
Gas booster stations	34
Electro-hydraulic gas booster and MAX-Compression Hydrogen compression system	35
<b>Air Amplifier Type PLV</b>	
Concept, system solutions, function and benefits	36
Product range overview, Type coding	37
» MPLV Series	38
» MPLV 2-Stations	40
» MPLV 4-Stations	41
» SPLV Series	42
» SPLV 2-Stations	44
» SPLV 3-Stations	45
» GPLV Series	46
» GPLV 2-Stations	48
» GPLV 5-Stations	49
Flow capacity and technical features	50
<b>Additional services</b>	
Service and testing services	51
Hydraulics and pneumatics	52
High Pressure Technology and Testing Equipment	54

# » Maximator worldwide - At your side, everywhere

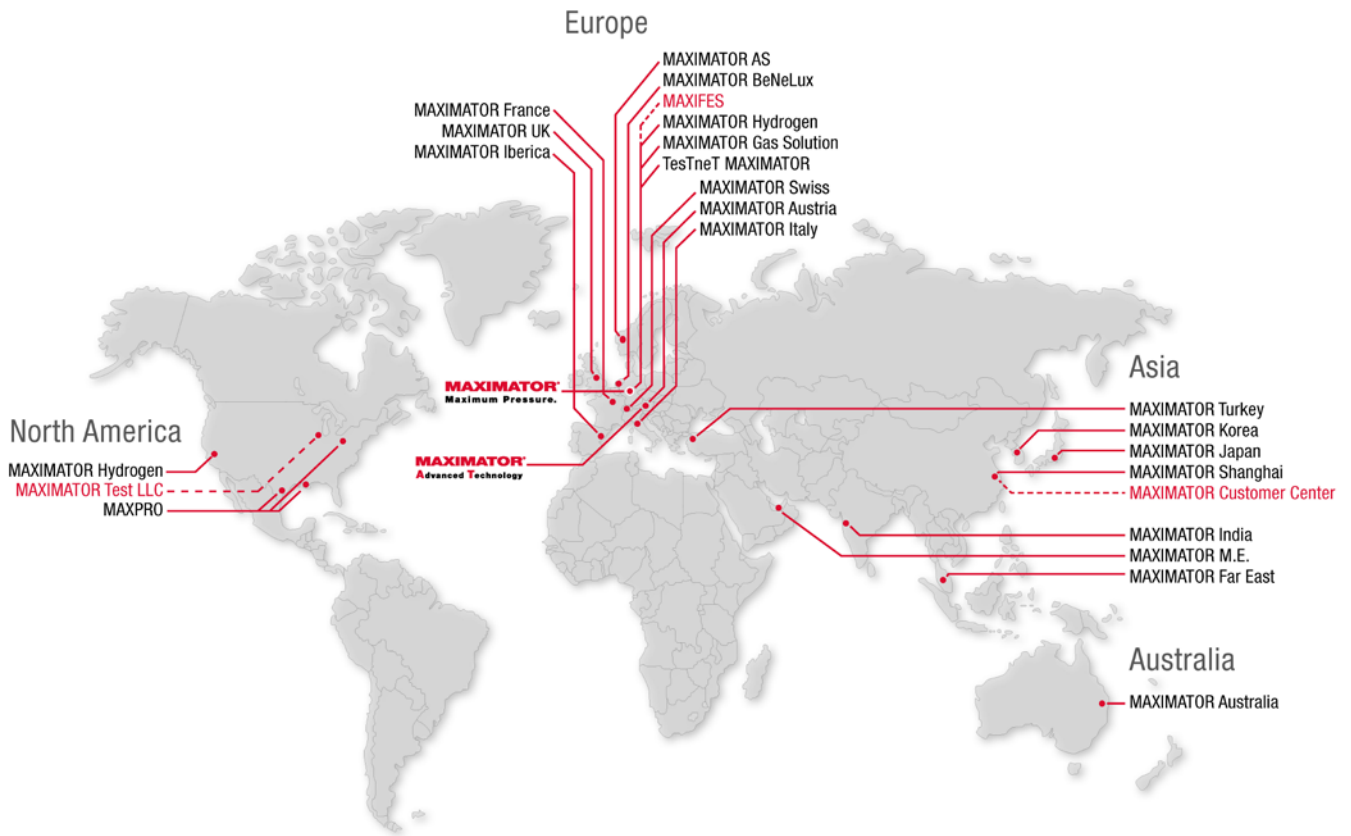

As an internationally leading company specialising in high-pressure technology, Maximator develops high-performance air driven gas boosters for a variety of uses and applications.

For decades we have supported well-known companies in the automotive and supply industry, as well as the chemical, plastics, oil and gas industries.

In addition to air driven gas boosters and air amplifiers, we also produce high pressure pumps and high-pressure technology such as valves, fittings, pressure switches and other components.

We also offer extensive services in the field of high-pressure testing and production technology.

Our devices comply with the machinery and ATEX directives and, on request, with the NACE specifications. Depending on the application, designs with FDA-compliant seals are also possible. Please do not hesitate to contact us about your task.

We follow strict quality guidelines certified according to ISO 9001. In order to ensure the continuous further development of our products, we maintain a close cooperation with our customers as well as with material and component suppliers.

With four technical offices in Germany and qualified partner companies worldwide, we can offer optimal customer service. A total of over 400 qualified, highly motivated employees work at our production centre in Nordhausen.

# Gas booster

## » Type DLE

### High pressure gas boosters – the Maximator concept

The Maximator high pressure gas boosters are suitable for the oil free compression of gases and air. Industrial gases like argon, helium, nitrogen and hydrogen can be compressed to operating pressures of 2400 bar (36000 psi) and oxygen up to 350 bar (5075 psi), depending on the application. Air driven gas boosters are an efficient alternative instead of electrically driven products and can be used in explosion-proof areas (according to 2014/34/EU).

### The Gas boosters in detail

#### Features at a glance

- » Pressure regulation via manual pressure regulator or pneumatically actuated valve
- » Operation with compressed air allows use in explosion-proof areas
- » Gas booster automatically stops operating upon reaching pre-selected final pressure
- » Gas booster restarts automatically to compensate leaks
- » No power consumption during long pressure holding periods
- » No heat generation during pressure holding period
- » Easy installation and trouble-free handling of gas boosters
- » Low maintenance thanks to reliable, easy-to-install devices
- » Effective cooling of the high pressure cylinders through integrated exhaust air cooling

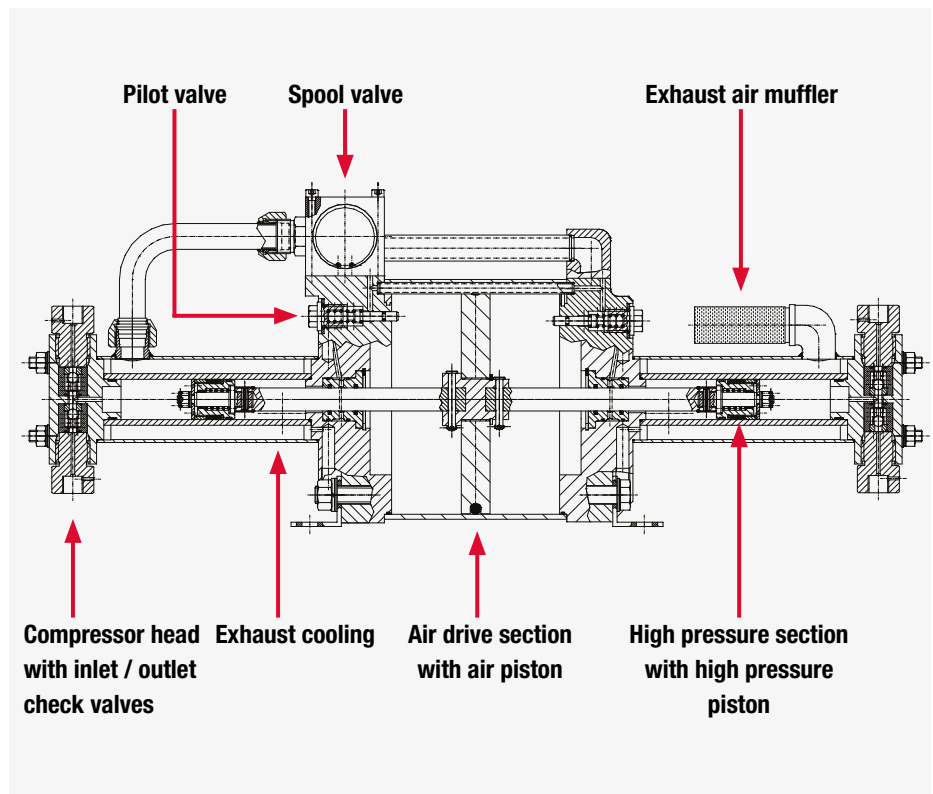

### Function and operation

The Maximator gas boosters' operating principle is similar to a pressure intensifier. A large air piston is charged with low pressure (air piston) and works on a small area with high pressure (high pressure piston).

The continuous operation is achieved by a pilot operated 4/2 way valve (spool valve). The spool valve applies the drive air alternately to the upper and bottom surface of the air piston.

The spool is piloted through two 2/2 way valves (pilot valves) which are mechanically actuated through the air piston in its end positions. The pilot valves charge and discharge the spool chamber.

The high pressure piston supported by the check valves (inlet check valve and outlet check valve) delivers the flow.

The outlet pressure is directly related to the set air drive pressure. According to the formulas indicated in the technical features table for the gas boosters, the static end pressure can be calculated.

At this pressure a force balance between drive section and gas section is achieved. The booster stalls when this end pressure is reached, and does not consume any further air.

A pressure drop at the high pressure side or a pressure increase at the drive side starts the booster automatically until the force balance is achieved again.

Additionally the Maximator boosters can be switched on and off automatically through Maximator air pilot switches, contact gauges or external control devices.

# » Product range overview

## The series and its functions

Maximator gas boosters offer the right solution for every application. As a result of the wide range of models it is possible to select the optimum booster for each application. Single stage or two stage boosters, single acting, double acting, quadruple acting or a combination of these models can be used to achieve different operating pressures and flow capacities. They are suitable for different or stepped flow rates as well as for different maximum allowable operating pressures. In addition to gas boosters with a  $\varnothing 160$  mm drive (DLE series), Maximator also offers various models with a  $\varnothing 200$  mm drive (8DLE series) for high volume flows.

### 160 mm - Drive (Standard DLE-Series):

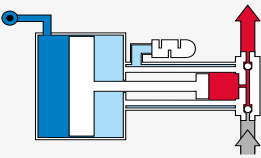
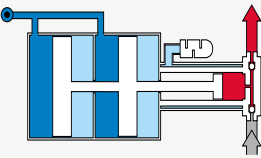
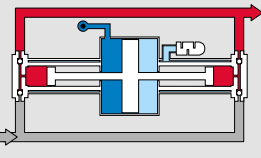
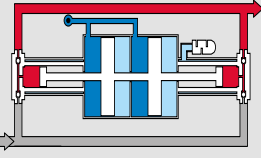
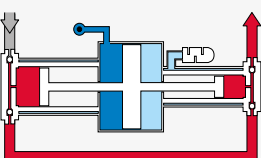
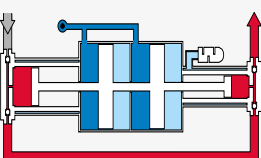
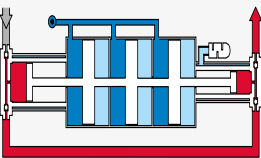
One Air Drive Section		Two Air Drive Sections	
Pattern	Design Pressure ratio max. working pressure Type	Pattern	Design Pressure ratio max. working pressure Type
	Single stage - single acting from 1:2 up to 1:75 max. 750 bar DLE 2-1, DLE 5-1, DLE 15-1, DLE 30-1, DLE 75-1		Single stage - single acting from 1:4 up to 1:150 max. 1500 bar DLE 2-1-2, DLE 5-1-2, DLE 15-1-2, DLE 30-1-2, DLE 75-1-2
	Single stage - double acting from 1:2 up to 1:75 max. 1500 bar DLE 2, DLE 5, DLE 15, DLE 30, DLE 75		Single stage - double acting from 1:4 up to 1:150 max. 1500 bar DLE 2-2, DLE 5-2, DLE 15-2, DLE 30-2, DLE 75-2
	Two stage from 1:2 / 1:5 up to 1:30 / 1:75 max. 1500 bar DLE 2-5, DLE 5-15, DLE 5-30, DLE 15-30, DLE 15-75, DLE 30-75		Two stage - double acting from 1:4/1:10 up to 1:60/1:150 max. 2100 bar DLE 2-5-2, DLE 5-15-2, DLE 5-30-2, DLE 15-30-2, DLE 15-75-2, DLE 30-75-2
Three Air Drive Sections			
	Two stage - double acting 1:30 / 1:75 max. 2400 bar DLE 30-75-3		

### 200 mm - Drive (8DLE-Series for high volume flow applications):

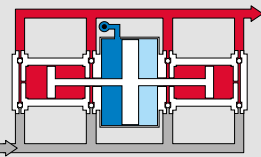
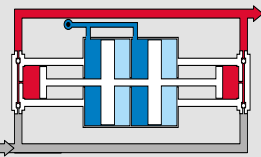
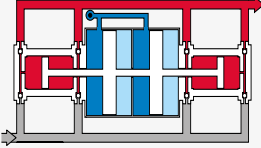
One Air Drive Section		Two Air Drive Sections	
	Single stage - quadruple acting 1:1,65 max. 300 bar 8DLE 1,65		Single stage - double acting 1:6 max. 40 bar 8DLE 6
			Single stage - quadruple acting 1:3 max. 40 bar 8DLE 3

## » Type coding

**X DLE XX - XX - X - X - XX - X**  
**\_ DLE 75 -1- 2 - GG - C**

### Size of air drive section:

- » no information = 160 mm drive size
- » 8 = 200 mm drive size

### Model with pressure ratio:

- » DLE = gas booster
- » 75 = pressure ratio (1:75)

### Acting type:

- » 1 = single acting
- » no information = multiple acting

### Number of air drive sections:

- » no information = 1 Air drive section\*
- » 2 = 2 Air drive sections (doubles the pressure ratio)
- » 3 = 3 Air drive sections (triples the pressure ratio)

### High pressure connections (Gas inlet / Gas outlet):

- » G = G (BSPP) -Thread (Standard; GG = BSPP thread inlet/outlet)
- » U = high pressure connection (UNF)
- » N = NPT

### Options, e.g. for:

- » C = carbon dioxide
- » S = oxygen
- » H2 = hydrogen

### Examples:

#### **DLE 75-1-2-GG-C**

Single stage, single acting gas booster with two air drive sections, with BSP connections, for carbon dioxide

#### **DLE 5-NN**

Single stage, double acting gas booster with one air drive section, with NPT connections

#### **DLE 15-75-2-UU**

Double stage, double acting gas booster with two air drive sections, with high pressure connections

#### **DLE 30-1-GG**

Single stage, single acting gas booster with one air drive section, with BSP connections

#### **8 DLE 1,65-GG**

200 mm drive size, single stage, quadruple acting gas booster with one air drive section, with BSP connections

\* does not apply to 8DLE-Series

# » General information

## Gas booster installation

Maximator gas boosters can always be operated in any position, although the horizontal position is most effective in preserving the seals. For fault free operation, the devices should be equipped with fittings and tubing which are suitable for the desired pressure range. The connection sizes should never be reduced.

The connections of Maximator gas booster are available as BSPP threads and optionally as NPT threads. Both threads are suitable for pressures up to 1050 bar (15000 psi). For applications above 1050 bar only medium and high pressure connections according to Maximator specifications are permitted.

We offer medium pressure connections "M" up to 1550 bar (22500psi) and high pressure connections "H" up to 4500 bar (65000 psi) available in sizes 1/4" (4M/4H), 3/8" (6M/6H) and 9/16" (9M/9H).

Please consult the Maximator Valves, Fittings and Tubing catalog, „Tools and Installation“ chapter for more detailed information about the Maximator medium and high pressure connections.

## Before starting operation

The connection for the compressed air drive is located on the spool cycling valve housing. Many types (except the 8DLE Series types) have a second connection (marked by „X“) for direct pilot valve air. This is used for switching the gas booster on and off via solenoid valves with small nominal size.

The pilot valve air must be connected directly to the gas booster, unregulated and filtered. If the direct pilot valve air is not connected, the gas booster will not work.

Before starting operation, a compressed air filter with a water separator should be mounted in the air drive line prior to the gas booster. We offer the technical accessories with different nominal diameters according to the drive size of the gas booster (160 mm drive or 200 mm drive).

In general Maximator gas boosters do not require a compressed air oiler, as they are treated with special grease during assembly. An upstream connection of an oiler is recommendable if the gas booster is to be operated with very dry air (see also FEC option for operating the gas booster with dry drive air or nitrogen).

After operating the gas booster with oiled compressed air, it is advisable to retain this lubrication for subsequent applications. Should you change to un-lubricated compressed air, the gas booster should be retreated with special grease.

## Drive air

In order to ensure optimal durability for the seal and guide elements, the drive air should meet the specifications of quality grades from 3 to 4 (solids/ water / oil):

### Air quality in accordance with ISO 8573-1

Specification	Value
max. compressed air purity of oil (class 4):	5 mg/m <sup>3</sup>
max. solids, particle concentration:	5 mg/m <sup>3</sup>
max. pressure dew point at moisture (class 4)*:	+3 °C

\* For drive media temperature of 20°C. Other values may be required depending on the temperature of the drive media.

## Recommended Gases

Proper operation and efficiency of the gas booster depends mainly on the quality of the process gas as well as the compatibility of the seals. Maximator gas boosters are designed for compressing a wide range of industrial gases. Please refer to the process fluids table on page 31 of this catalog for more detailed information.

To prevent damage to both the inlet and outlet check valves and the high pressure seal, a filter with a mesh width of less than 10 µm should be fitted to the gas inlet connection.

## Temperatures

The standard operating temperatures of Maximator gas booster range between -20 °C and +100 °C. For types DLE 2 and DLE 5, operating temperature limits are -20 °C to +60 °C due to the aluminum content in the high pressure section. Please note that the compression of gases produces additional heat. If you should require further assistance please contact our application team.

## Cooling

The compression of gases creates heat as a by-product. Depending on the compression ratio (= gas outlet pressure / gas inlet pressure) and which gas is compressed, very high temperatures of several hundred °C can arise at the moment of maximum compression.

Due to their design, the gas boosters achieve compression ratios of up to 1:100 and are designed in continuous operation for temperatures between -20 °C to + 60 °C or + 100 °C (see temperatures). The DLE series gas boosters (with compression ratio  $i > 1:2$ ) are equipped with an integrated, active exhaust air cooling system so that the compression process does not cause excessively high temperatures in the device.

## » General information

Maximator gas boosters use the expanded, cold exhaust air (which is typically less than +5 °C) from the compressed air drive and direct it around the high-pressure cylinder(s) of the gas booster. This effectively dissipates the compression heat from the device. In most applications, the integrated cooling is sufficient to protect the gas booster and the downstream processes.

For applications where high compression ratios are required and this results in an unacceptably high compression temperature, it is advisable to design the compression process in several stages. Depending on the process conditions, Maximator air or water coolers can also be used to reduce the temperature input to an acceptable level.

### Emission protection

High pressure gas boosters can cause emissions such as noise or air contamination from the process gas.

### Parallel and series operation

Maximator gas boosters are compressed air driven piston compressors that are designed to generate high gas pressures with comparatively low flow rates. The use of gas boosters with a 200 mm drive section is therefore recommended for volume flow-intensive applications, as these devices offer larger stroke and flow volumes. Alternatively, several gas boosters of one type can be operated in parallel.

By connecting the Maximator gas boosters in series, a compression process can be designed in several stages. This is recommended if, for example, a single-stage solution would generate compression temperatures that are too high or the required volume flow cannot be achieved. When designing such complex systems and selecting the specific gas boosters, it is advisable to consult Maximator's application specialists.

### Replacement and spare parts

In order to make the maintenance of the gas boosters as simple and efficient as possible, Maximator has designed spare part sets for the spool section, air drive section, high pressure section and inlet and outlet valves. The spare part sets contain all of the original parts required for the maintenance.

All Maximator gas boosters are delivered with a connection and sectional drawing including a parts list. On this drawing, all spare part kits required for the maintenance of the devices are listed with the respective order code. Only spare parts according to Maximator specifications are to be used.

### Process fluids

Maximator gas boosters are designed for the oil free compression of technical gases. The devices compress gases such as argon, helium, hydrogen or nitrogen. The process fluids table on page 31 in this catalog gives an overview of the recommended sealing options for typical gases.

The compression of gases, which form an explosive atmosphere when mixed with the ambient air, as well as the compression of toxic or flammable gases creates considerations for requirements of the materials of the wetted parts and the compression process itself. Further information can be found in the operating instructions.

### Media separation

With compressed air driven gas boosters, it should be noted that both the drive - and the process media are usually in a gaseous state. A mixture of both media would cause this gas mixture to be discharged through the exhaust silencer to the ambient. This contamination could possibly cause damage. It is therefore essential to prevent the drive gas from mixing with the process gas.

For this reason, all Maximator gas boosters are equipped with an integrated media separation. In this way, potential leaks on both the drive side and the process side are diverted from the device via separate leakage lines. With appropriate piping and drainage of leaks it can be ensured that process gases are not contaminated and no harmful emissions can contaminate the environment of the devices.

### Purging

Due to the design of piston compressors, small leaks occur on the high-pressure side. This leakage has no effect on the functionality of the device, but may have to be taken into account in the risk assessment of a system.

With most process fluids, it is sufficient to discharge the leakage into a non-critical area in a controlled manner via the corresponding leakage connection. However, if gases are compressed that react with the ambient air or, for example, like hydrogen, which can form an explosive mixture, it is possible to efficiently prevent the process gas from being mixed with the ambient air by purging, for example with an inert gas.

All Maximator gas boosters of the DLE series are equipped with an integrated flushing connection. This connection is directly connected to the rear piston space, which means that this space can be actively flushed with an inert gas (e.g. nitrogen).



## » General information

This means that even highly reactive gases can be compressed without risk. Further information on the recommended volume flow for purging the devices can be found in the installation and operating instructions.

### Stroke frequencies

Compared with electric compressors, air driven gas boosters do not convert a rotational movement into a translational movement to drive the high-pressure piston. By alternately applying compressed air to each side of drive piston, Maximator gas boosters perform oscillating, translational movements - both in the air drive and high-pressure section.

This movement is called a stroke and the number of strokes per minute is defined as stroke frequency. Maximator gas boosters can achieve stroke frequencies of over 100 strokes per minute when idling (with a free gas outlet). The highest effectivity is achieved with stroke frequencies of 30 to 60 strokes per minute.

To monitor or document the number of strokes, Maximator boosters can be fitted with pneumatic stroke counters. These may also be used in explosion protection areas.

### Use in potentially explosive areas

Maximator gas booster can be used in potentially explosive areas if they have an EX symbol and a declaration of conformity for 2014/34/EU is available.

Detailed information about the use of Maximator gas boosters in potentially explosive areas can be found in the installation and operating instructions.

### Gas inlet pressure vs. gas outlet pressure

Maximator gas booster require a certain gas inlet pressure in order to be able to achieve the specified gas outlet pressure.

This means that the gas inlet pressure has a direct influence on the gas outlet pressure and the volume flow of the device at the required operating point.

In many applications there is no constant gas inlet pressure supply available, for example when using gas cylinders as supply source, so that the performance of the devices changes accordingly as the gas inlet pressure drops during the operation. This is particularly important for filling and testing applications.

### Type coding

The type coding of Maximator gas boosters contain information on the pressure ratio and operating principle, the number of air pistons, connections and other options. Information on the tyoe code can be found in the information on our different booster series.

### Scope of delivery

The following documents are included in the scope of delivery of every Maximator gas booster:

- » General drawing of the device
- » Assembly and operating instructions including:
  - » Declaration of incorporation according to the Machinery Directive
  - » Declaration of conformity according to explosion protection directive

Certificates such as Material certificates or test certificates (e.g. acceptance reports) are available on request.

# » Fields of applications

## Fields of applications for high pressure gas boosters

### Gas compression with constant gas inlet pressure

Maximator gas boosters are ideally suited for the compression of gases from low-pressure gas supply systems or gas generators. Thus, the gas supply can be increased to the required working pressure for different applications:

- » Filling of gas bottles with technical gases (e.g. oxygen, nitrogen, helium, argon, etc.)
- » Compression of gases from nitrogen or oxygen generators for gas cylinder filling or process supplies
- » Compression of hydrogen e.g. from an electrolyzer
- » High pressure gas supply for research and production applications in the life science sector
- » Gas compression of vaporized gas from liquid gas tank supply systems

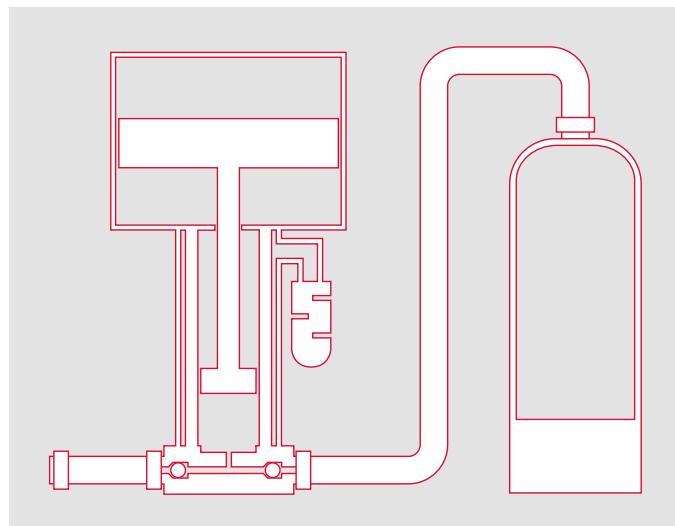

### Gas compression with variable gas inlet pressure

A typical application for Maximator gas boosters is to increase the pressure of gases from gas cylinders or gas cylinder bundles. Depending on the application, more gas can be made available for the various applications at high pressure.

- » Gas transfer for optimal use of the gas cylinder or the gas cylinder bundle
- » Gas compression for breathing air systems or gas mixing systems for technical diving or rescue services
- » Liquid gas transfer
- » Stationary or mobile nitrogen charging of shock absorbers, gas pressure springs, hydraulic accumulators or suspension systems

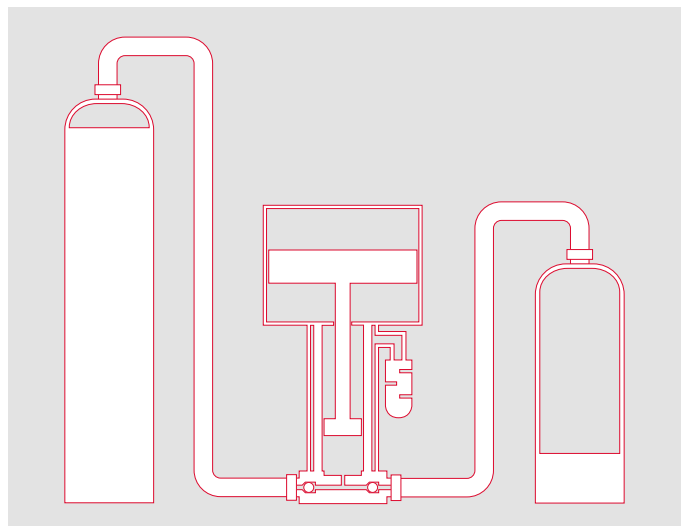

# » Fields of applications

## Gas compression for laboratory and production applications

Maximator gas boosters are ideally suited for compressing gases up to pressures of 2400 bar in production and research applications.

- » Filling of airbag systems with helium
- » High pressure gas supply for autoclave applications
- » Compression and pressure regulation of  $N_2$  or  $CO_2$  for gas assisted molding applications in the plastics industry
- » High pressure gas supply for physical foaming with  $N_2$ ,  $CO_2$ , propane or butane
- » High pressure nitrogen supply for mirror chambers of laser cutting systems
- » Purge and recovery applications for expensive or hazardous gases (e.g. argon, helium, SF<sub>6</sub>, xenon, etc.)
- » High pressure supply for hydrogen applications and hydrogen research
- » Gas supply for mechanical seals in the chemical, petrochemical and life science sectors

## Gas compression for high pressure testing applications

Increasing quality requirements mean that components that are under pressure must also be tested with gas - and in many cases also with the respective process gas. In these cases in particular, the high flexibility of Maximator gas boosters and the safe operation of the devices are major advantages for users.

- » Gas supply for pressure and leak tests with a wide variety of technical gases and gas mixtures
- » High pressure supply for helium leak detection applications
- » Gas compression for calibration applications
- » High pressure supply for adjusting valves with gas
- » Functional tests with gases under high pressure

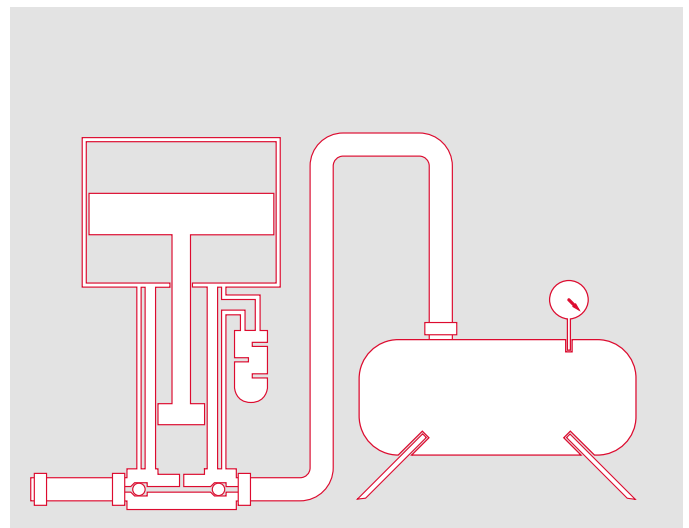
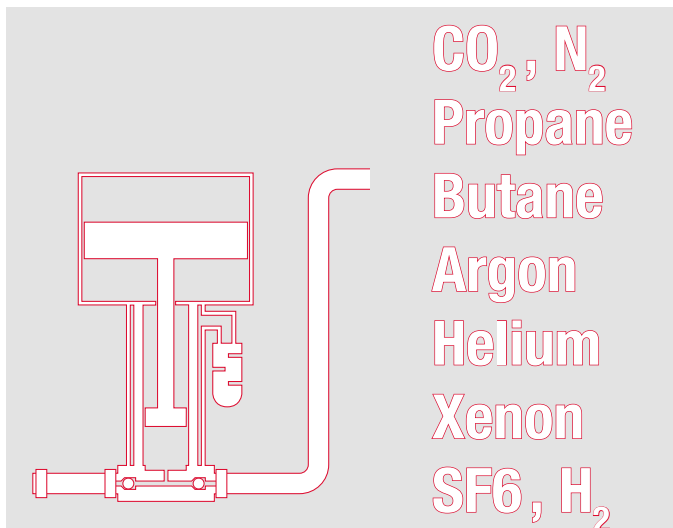

# Gas booster Series

## » DLE...-1 single stage, single acting, 1 air drive section

Maximator gas boosters in single stage, single acting design with 1 air drive piston are suitable for the use in hazardous areas of Zone 1, device group II, device category 2G, explosion group II B. The compact and effective gas boosters with one air drive and one high pressure section are available in different pressure ratios. They are ideal for mobile applications with operating pressures of up to 750 bar.

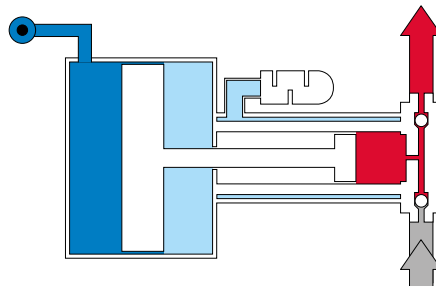

Working principle DLE 15-1

### DLE...- 1

- » Single acting
- » Single stage
- » With one air drive section
- » Working pressure up to 750 bar (10875 psi)
- » Formula for gas outlet pressure:  $p_B = p_L \cdot i$
  
- » Material: compressor head, high pressure cylinders and high-pressure pistons as well as fittings made of aluminum (DLE 2-1 / DLE 5-1) or stainless steel (DLE 15-1 / DLE 30-1 / DLE 75-1); PTFE seals.
  
- » All gas boosters are equipped with media separation (Z) and flushing connection (SFP) (Z-connections, SFP = G 1/8 ").
  
- » Active cooling from DLE 5-1 included as standard
  
- » Suitable for air drive pressures ( $p_L$ ) from 1 to 10 bar (14.5 to 145 psi)

### Options for DLE ... - 1

- » Special sealing options for high and low temperature applications (-40 up to +120 °C)
- » ECO-Option to reduce the air consumption
- » EXIIC-Option (Device group IIC)
- » FEC-Option for dry compressed air or nitrogen drive
- » C-Option for CO<sub>2</sub> applications
- » S-Option for O<sub>2</sub> applications
- » H2-Option for H<sub>2</sub> applications
- » Various connections for inlet / outlet (BSP, NPT, UNF)

Type	Pressure ratio $i^*$	Stroke volume**		max. working pressure $p_B^{***}$		min. gas inlet pressure $p_{Amin}$		max. gas inlet pressure $p_{Amax}$	
		[cm <sup>3</sup> ]	[in <sup>3</sup> ]	[bar]	[psi]	[bar]	[psi]	[bar]	[psi]
DLE 2-1	1:2	922	56,3	20	290	0	0	20	290
DLE 5-1	1:5	373	22,8	50	725	2	29	50	725
DLE 15-1	1:15	122	7,4	150	2175	7	102	150	2175
DLE 30-1	1:30	60	3,7	300	4350	15	218	300	4350
DLE 75-1	1:75	25	1,5	750	10875	35	508	750	10875

\* Pressure ratio of air drive piston surface area to output piston surface area

\*\* Calculated stroke volume

\*\*\* Maximum permissible static working pressure

$p_A$  = Gas inlet pressure

$p_B$  = Working pressure

$p_L$  = Air drive pressure

$i$  = Pressure ratio

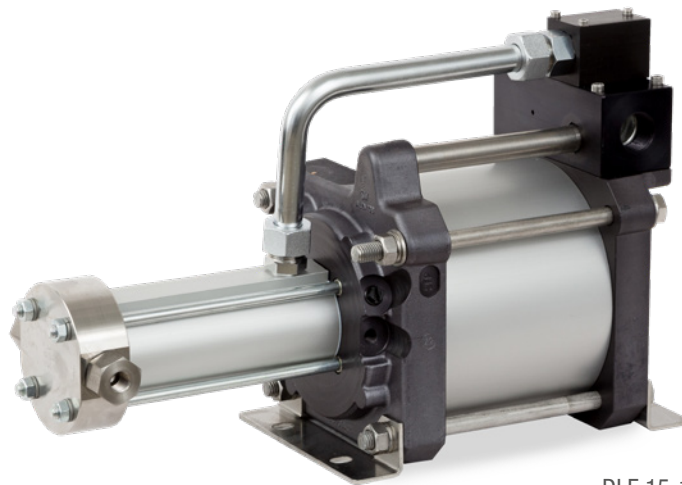

DLE 15-1

**Accessories:**

- » Air control unit
- » Pressure switches
- » Cooler
- » Spare part sets
- » Valves, Fittings, Tubing
- » Gas booster stations ready for connection according to specification

Further options and accessories on request.

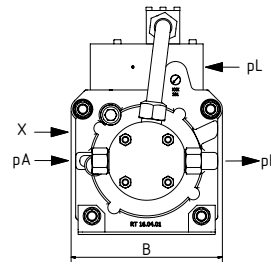
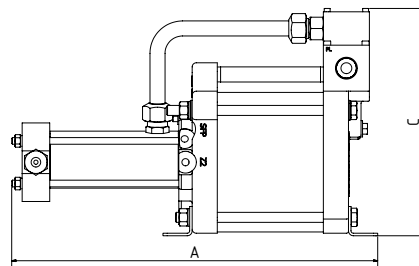

Type	Connections [in]			Dimensions [mm]			Weight [kg]
	Drive air	Inlet A	Outlet B	A	B	C	
DLE 2-1	G 3/4	G 1/2	G 1/2	435	181	272	15,3
DLE 5-1	G 3/4	G 1/2	G 1/2	433	181	272	12,8
DLE 15-1	G 3/4	G 1/4	G 1/4	438	181	272	13
DLE 30-1	G 3/4	G 1/4	G 1/4	438	181	272	12,6
DLE 75-1	G 3/4	G 1/4	G 1/4	441	181	272	12,9

# Gas booster Series

## » DLE...-1-2 single stage, single acting, 2 air drive sections

Maximator gas boosters in single stage, single acting design with 2 air drive pistons are suitable for the use in hazardous areas of Zone 1, device group II, device category 2G, explosion group II B. The effective gas boosters with two air drive sections and one high pressure section are available in different pressure ratios. These devices are specially designed for applications with a high operating pressure but only low available air drive pressure.

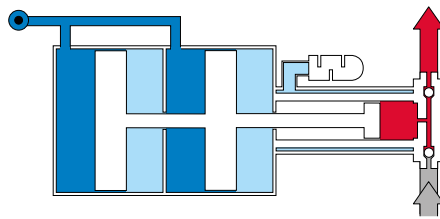

Working principle DLE 15-1-2

### DLE ... -1 - 2

- » Single acting
- » Single stage
- » With two air drive sections
- » Working pressure up to 1500 bar (21750 psi)
- » Formula for gas outlet pressure:  $p_B = p_L \cdot i$
- » Material: compressor head, high pressure cylinders and high-pressure pistons as well as fittings made of aluminum (DLE 2-1-2/ DLE 5-1-2) or stainless steel (DLE 15-1-2/ DLE 30-1-2/DLE 75-1-2); PTFE seals.
- » All gas boosters are equipped with media separation (Z) and flushing connection (SFP) (Z-connections, SFP = G 1/8 ").
- » Active cooling from DLE 5-1-2 included as standard
- » Suitable for air drive pressures ( $p_L$ ) from 1 to 10 bar (14.5 to 145 psi)

### Options for DLE ... - 1-2

- » Special sealing options for high and low temperature applications (-40 up to +120 °C)
- » ECO-Option to reduce the air consumption
- » EXIIC-Option (Device group IIC)
- » FEC-Option for dry compressed air or nitrogen drive
- » C-Option for CO<sub>2</sub> applications
- » S-Option for O<sub>2</sub> applications
- » H2-Option for H<sub>2</sub> applications
- » Various connections for inlet / outlet (BSP, NPT, UNF)

Type	Pressure ratio $i^*$	Stroke volume**		max. working pressure $p_B^{***}$		min. gas inlet pressure $p_{Amin}$		max. gas inlet pressure $p_{Amax}$	
		[cm <sup>3</sup> ]	[in <sup>3</sup> ]	[bar]	[psi]	[bar]	[psi]	[bar]	[psi]
DLE 2-1-2	1:4	922	56,3	40	580	0	0	40	580
DLE 5-1-2	1:10	373	22,8	100	1450	4	58	100	1450
DLE 15-1-2	1:30	122	7,4	300	4350	10	145	300	4350
DLE 30-1-2	1:60	60	3,7	600	8700	20	290	600	8700
DLE 75-1-2	1:150	25	1,5	1500	21750	50	725	1500	21750

\* Pressure ratio of air drive piston surface area to output piston surface area

\*\* Calculated stroke volume

\*\*\* Maximum permissible static working pressure

$p_A$  = Gas inlet pressure

$p_B$  = Working pressure

$p_L$  = Air drive pressure

$i$  = Pressure ratio

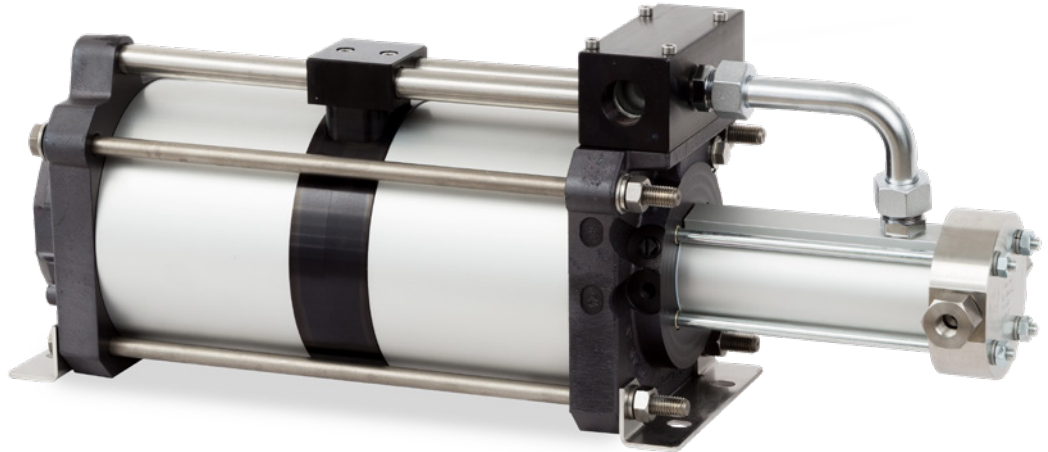

DLE 15-1-2

**Accessories:**

- » Air control unit
- » Pressure switches
- » Cooler
- » Spare part sets
- » Valves, Fittings, Tubing
- » Gas booster stations ready for connection according to specification

Further options and accessories on request.

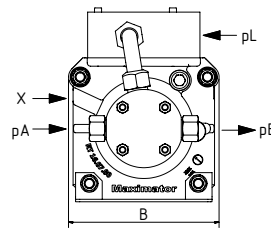
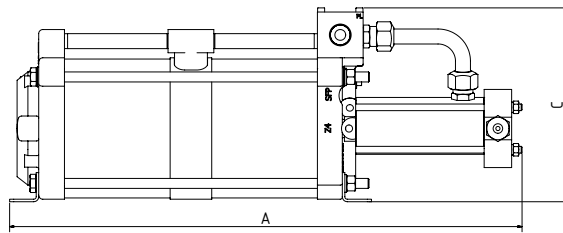

DLE 2-1-2\*\*\*\*

Type	Connections [in]			Dimensions [mm]			Weight [kg]
	Drive air	Inlet A	Outlet B	A	B	C	
DLE 2-1-2	G 3/4	G 1/2	G 1/2	611	181	272	25,7
DLE 5-1-2	G 3/4	G 1/2	G 1/2	611	181	233	21
DLE 15-1-2	G 3/4	G 1/4	G 1/4	616	181	233	21,5
DLE 30-1-2	G 3/4	G 1/4	G 1/4	616	181	233	21,4
DLE 75-1-2	G 3/4	G 1/4	G 1/4 <sup>①</sup>	619	181	233	20

① High pressure gas booster with outlet connections type BSPP or NPT are suitable for outlet pressures of up to 1050 bar (15000 psi). For higher outlet pressures, the gas boosters must be ordered with high pressure connections according to the required pressure range.

\*\*\*\* The position and dimensions of the connections can be found in the product drawings and data sheets.

# Gas booster Series

## » DLE... single stage, double acting, 1 air drive section

Maximator gas boosters in single stage, double acting design with 1 air drive piston are suitable for the use in hazardous areas of Zone 1, device group II, device category 2G, explosion group II B. The compact and effective gas boosters with one air drive and two high pressure sections are available in different pressure ratios. They are ideal for mobile applications with a comparatively high volume flow.

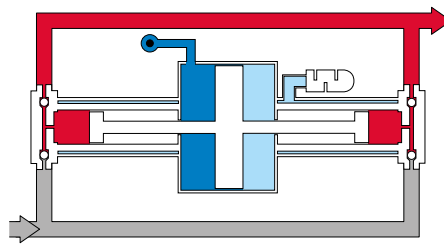

Working principle DLE 15

### DLE ...

- » Double acting
- » Single stage
- » With one air drive section
- » Working pressure up to 1500 bar (21750 psi)
- » Formula for gas outlet pressure:  

$$p_B = p_L \cdot i + p_A$$
- » Material: compressor head, high pressure cylinders and high-pressure pistons as well as fittings made of aluminum (DLE 2/ DLE 5) or stainless steel (DLE 15/DLE 30/DLE 75); PTFE seals.
- » All gas boosters are equipped with Media separation (Z) and flushing connection (SFP) (Z-connections, SFP = G 1/8 ").
- » Active cooling from DLE 5 included as standard
- » Suitable for air drive pressures ( $p_L$ ) from 1 to 10 bar (14.5 to 145 psi)

### Options for DLE ...

- » Special sealing options for high and low temperature applications (-40 up to +120 °C)
- » EXIIC-Option (Device group IIC)
- » FEC-Option for dry compressed air or nitrogen drive
- » C-Option for CO<sub>2</sub> applications
- » S-Option for O<sub>2</sub> applications
- » H2-Option for H<sub>2</sub> applications
- » Various connections for inlet / outlet (BSP, NPT, UNF)

Type	Pressure ratio $i^*$	Stroke volume**		max. working pressure $p_B^{***}$		min. gas inlet pressure $p_{Amin}$		max. gas inlet pressure $p_{Amax}$	
		[cm <sup>3</sup> ]	[in <sup>3</sup> ]	[bar]	[psi]	[bar]	[psi]	[bar]	[psi]
DLE 2	1:2	1844	112,5	40	580	0	0	40	580
DLE 5	1:5	746	45,5	100	1450	2	29	100	1450
DLE 15	1:15	244	14,9	300	4350	7	102	300	4350
DLE 30	1:30	120	7,3	600	8700	15	218	600	8700
DLE 75	1:75	50	3	1500	21750	35	508	1500	21750

\* Pressure ratio of air drive piston surface area to output piston surface area

\*\* Calculated stroke volume

\*\*\* Maximum permissible static working pressure

$p_A$  = Gas inlet pressure

$p_B$  = Working pressure

$p_L$  = Air drive pressure

$i$  = Pressure ratio



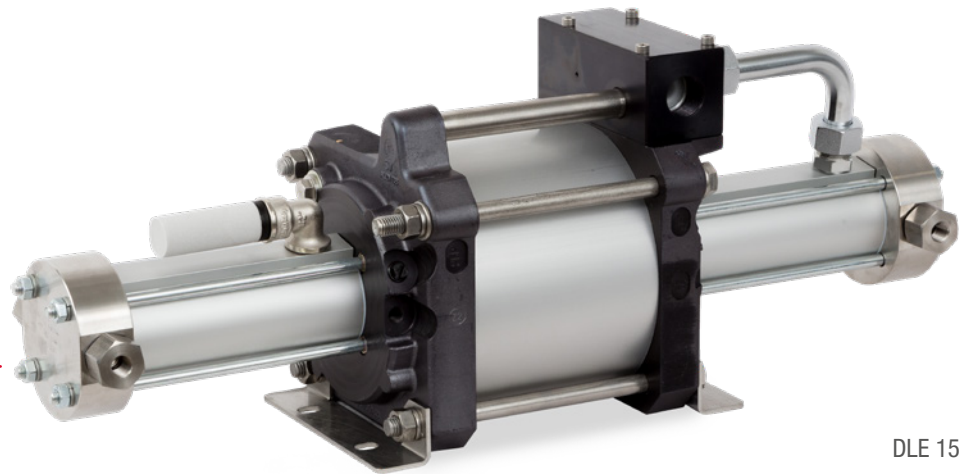

DLE 15

**Accessories:**

- » Air control unit
- » Pressure switches
- » Cooler
- » Spare part sets
- » Valves, Fittings, Tubing
- » Gas booster stations ready for connection according to specification

Further options and accessories on request.

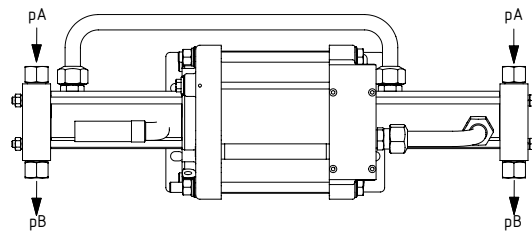
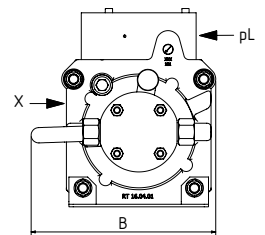
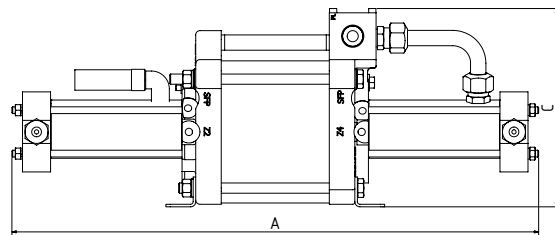

Type	Connections [in]			Dimensions [mm]			Weight [kg]
	Drive air	Inlet A	Outlet B	A	B	C	
DLE 2	G 3/4	G 1/2	G 1/2	610	181	272	20
DLE 5	G 3/4	G 1/2	G 1/2	609	219	233	18,1
DLE 15	G 3/4	G 1/4	G 1/4	619	217	233	19
DLE 30	G 3/4	G 1/4	G 1/4	619	217	233	19,4
DLE 75	G 3/4	G 1/4	G 1/4 <sup>①</sup>	625	217	233	18,2

① High pressure gas booster with outlet connections type BSPP or NPT are suitable for outlet pressures of up to 1050 bar (15000 psi). For higher outlet pressures, the gas boosters must be ordered with high pressure connections according to the required pressure range.

# Gas booster Series

## » DLE...-2 single stage, double acting, 2 air drive sections

Maximator gas boosters in single stage, double acting design with 2 air drive pistons are suitable for the use in hazardous areas of Zone 1, device group II, device category 2G, explosion group II B. The compact and effective gas boosters with two air drive and two high pressure sections are available in different pressure ratios. These devices are especially designed for applications in which a high operating pressure and a comparatively high volume flow are required, but only a low air drive pressure is available.

### DLE ... - 2

- » Double acting
- » Single stage
- » With two air drive sections
- » Working pressure up to 1500 bar (21750 psi)
- » Formula for gas outlet pressure:  

$$p_B = p_L \cdot i + p_A$$
- » Material: compressor head, high pressure cylinders and high-pressure pistons as well as fittings made of aluminum (DLE 2-2/ DLE 5-2) or stainless steel (DLE 15-2/ DLE 30-2/DLE 75-2); PTFE seals.
- » All gas boosters are equipped with media separation (Z) and flushing connection (SFP) (Z-connections, SFP = G 1/8 ").
- » Active cooling from DLE 5-2 included as standard
- » Suitable for air drive pressures ( $p_L$ ) from 1 to 10 bar (14.5 to 145 psi)

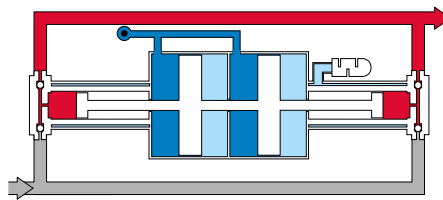

Working principle DLE 15-2

### Options for DLE ...

- » Special sealing options for high and low temperature applications (-40 up to +120 °C)
- » EXIIC-Option (Device group IIC)
- » FEC-Option for dry compressed air or nitrogen drive
- » C-Option for CO<sub>2</sub> applications
- » S-Option for O<sub>2</sub> applications
- » H2-Option for H<sub>2</sub> applications
- » Various connections for inlet / outlet (BSP, NPT, UNF)

Type	Pressure ratio $i^*$	Stroke volume**		max. working pressure $p_B^{***}$		min. gas inlet pressure $p_{Amin}$		max. gas inlet pressure $p_{Amax}$	
		[cm <sup>3</sup> ]	[in <sup>3</sup> ]	[bar]	[psi]	[bar]	[psi]	[bar]	[psi]
DLE 2-2	1:4	1844	112,5	40	580	0	0	40	580
DLE 5-2	1:10	746	45,5	100	1450	5	73	100	1450
DLE 15-2	1:30	244	14,9	300	4350	7	102	300	4350
DLE 30-2	1:60	120	7,3	600	8700	20	290	600	8700
DLE 75-2	1:150	50	3	1500	21750	45	653	1500	21750

\* Pressure ratio of air drive piston surface area to output piston surface area

\*\* Calculated stroke volume

\*\*\* Maximum permissible static working pressure

$p_A$  = Gas inlet pressure

$p_B$  = Working pressure

$p_L$  = Air drive pressure

$i$  = Pressure ratio



DLE 15-2

**Accessories:**

- » Air control unit
- » Pressure switches
- » Cooler
- » Spare part sets
- » Valves, Fittings, Tubing
- » Gas booster stations ready for connection according to specification

Further options and accessories on request.

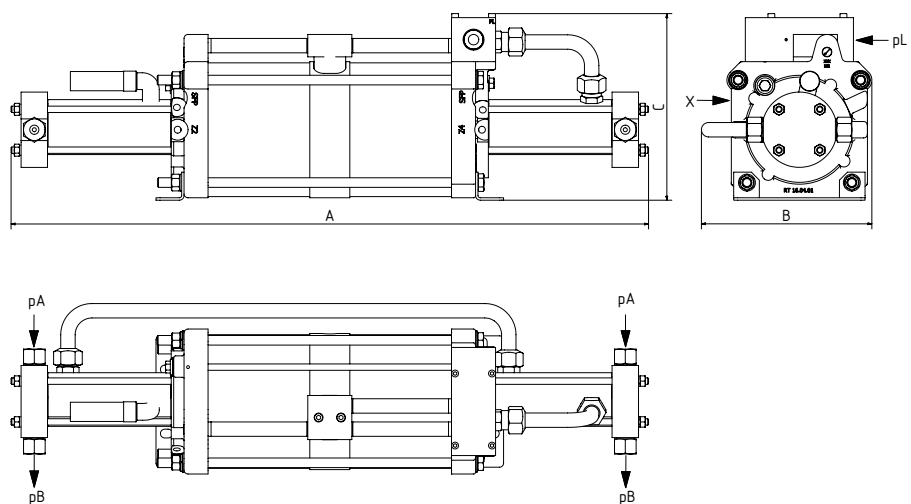

Type	Connections [in]			Dimensions [mm]			Weight [kg]
	Drive air	Inlet A	Outlet B	A	B	C	
DLE 2-2	G 3/4	G 1/2	G 1/2	787	181	272	27,5
DLE 5-2	G 3/4	G 1/2	G 1/2	786	220	233	25,9
DLE 15-2	G 3/4	G 1/4	G 1/4	796	213	233	25,3
DLE 30-2	G 3/4	G 1/4	G 1/4	796	213	233	24,1
DLE 75-2	G 3/4	G 1/4	G 1/4 <sup>①</sup>	802	213	233	25,3

① High pressure gas booster with outlet connections type BSPP or NPT are suitable for outlet pressures of up to 1050 bar (15000 psi). For higher outlet pressures, the gas boosters must be ordered with high pressure connections according to the required pressure range.

# Gas booster Series

## » DLE...-... two stage, 1 air drive section

Maximator gas boosters in two stage design with 1 air drive piston are suitable for the use in hazardous areas of Zone 1, device group II, device category 2G, explosion group II B. The compact and effective gas boosters with one air drive and two high pressure sections are available in different pressure ratios. By combining two different pressure stages and the effective cooling of both stages, even high compression ratios can be realised with just one gas booster.

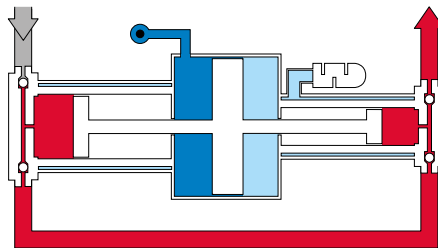

Working principle DLE 15-30

### DLE ...-...

- » Two stage
- » With one air drive section
- » Working pressure up to 1500 bar (21750 psi)
- » Formula for gas outlet pressure: see table
- » Material: compressor head, high pressure cylinders and high-pressure pistons as well as fittings made of aluminum (Stages 2 and 5) or stainless steel (Stages 15, 30 and 75); PTFE seals.
- » All gas boosters are equipped with media separation (Z) and flushing connection (SFP) (Z-connections, SFP = G 1/8 ").
- » Active cooling from DLE 2-5, stage 5 included as standard
- » Suitable for air drive pressures ( $p_L$ ) from 1 to 10 bar (14.5 to 145 psi)

### Options for DLE ... -...

- » Special sealing options for high and low temperature applications (-40 up to +120 °C)
- » EXIIC-Option (Device group IIC)
- » FEC-Option for dry compressed air or nitrogen drive
- » C-Option for CO<sub>2</sub> applications
- » S-Option for O<sub>2</sub> applications
- » H2-Option for H<sub>2</sub> applications
- » ZK option: intercooler for gas cooling after the first compression stage
- » Various connections for inlet / outlet (BSP, NPT, UNF)

Type	Pressure ratio $i_1 / i_2^*$	Stroke volume **		max. working pressure $p_B^{***}$		min. gas inlet pressure $p_{Amin}$		max. gas inlet pressure $P_{Amax}$
		[cm <sup>3</sup> ]	[in <sup>3</sup> ]	[bar]	[psi]	[bar]	[psi]	
DLE 2-5	1:2 / 1:5	922	56,3	70	1015	0	0	$0,8 \cdot p_L$
DLE 5-15	1:5 / 1:15	373	22,8	198	2870	2	29	$1,6 \cdot p_L$
DLE 5-30	1:5 / 1:30	373	22,8	330	4785	2	29	$0,5 \cdot p_L$
DLE 15-30	1:15 / 1:30	122	7,4	450	6525	7	102	$7,5 \cdot p_L$
DLE 15-75	1:15 / 1:75	122	7,4	875	12685	7	102	$2,5 \cdot p_L$
DLE 30-75	1:30 / 1:75	60	3,7	1050	15500	15	218	$12 \cdot p_L$

- \* Pressure ratio of air drive piston surface area to output piston surface area
- \*\* Calculated stroke volume
- \*\*\* Maximum permissible static working pressure
- $p_A$  = Gas inlet pressure
- $p_B$  = Working pressure
- $p_L$  = Air drive pressure
- $i$  = Pressure ratio

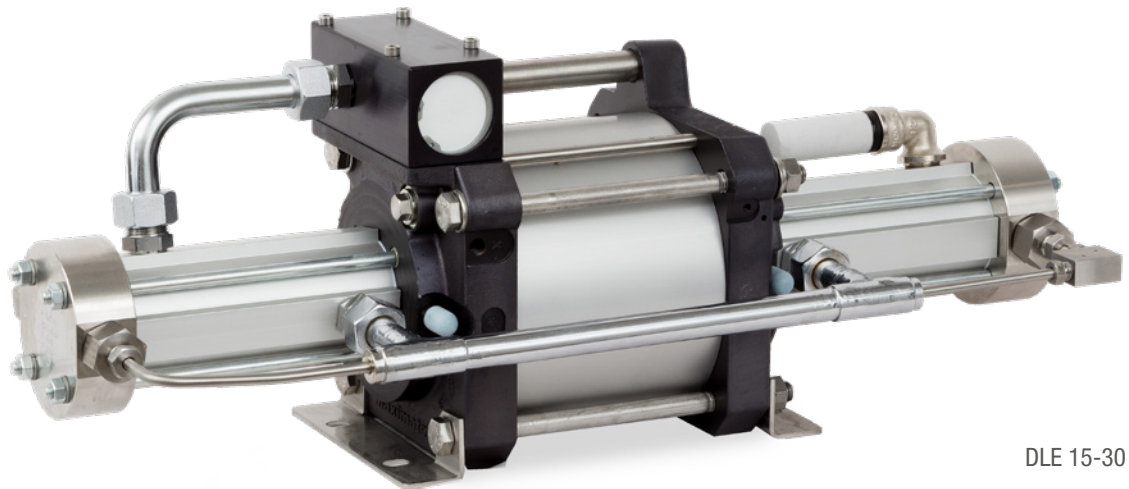

DLE 15-30

**Accessories:**

- » Air control unit
- » Pressure switches
- » Cooler
- » Spare part sets
- » Valves, Fittings, Tubing
- » Gas booster stations ready for connection according to specification

Further options and accessories on request.

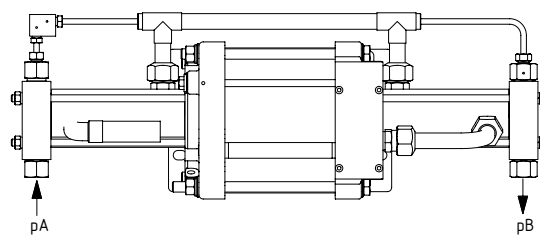
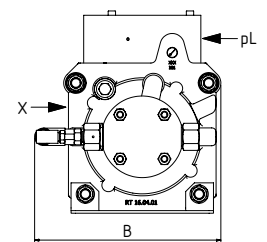
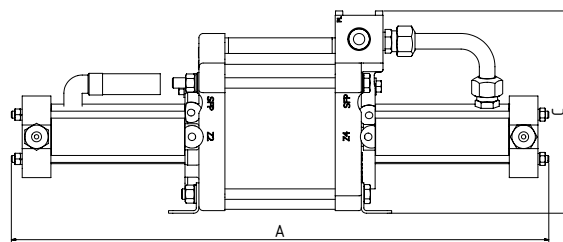

Type	Formula for gas outlet pressure $p_B$	Connections [in]			Dimensions [mm]			Weight [kg]
		Drive air	Inlet A	Outlet B	A	B	C	
DLE 2-5	$p_B = 5 \cdot p_L + 5/2 \cdot p_A$	G 3/4	G 1/2	G 1/2	611	235	233	19,8
DLE 5-15	$p_B = 15 \cdot p_L + 15/5 \cdot p_A$	G 3/4	G 1/2	G 1/4	614	259	233	18,5
DLE 5-30	$p_B = 30 \cdot p_L + 30/5 \cdot p_A$	G 3/4	G 1/2	G 1/4	614	259	233	19,5
DLE 15-30	$p_B = 30 \cdot p_L + 30/15 \cdot p_A$	G 3/4	G 1/4	G 1/4	619	215	233	19,8
DLE 15-75	$p_B = 75 \cdot p_L + 75/15 \cdot p_A$	G 3/4	G 1/4	G 1/4	622	215	233	19,3
DLE 30-75	$p_B = 75 \cdot p_L + 75/30 \cdot p_A$	G 3/4	G 1/4	G 1/4	622	215	233	18,2

❶ High pressure gas booster with outlet connections type BSPP or NPT are suitable for outlet pressures of up to 1050 bar (15000 psi). For higher outlet pressures, the gas boosters must be ordered with high pressure connections according to the required pressure range.

# Gas booster Series

## » DLE...-...-2 two stage, 2 air drive sections

Maximator gas boosters in two stage design with 2 air drive pistons are suitable for the use in hazardous areas of Zone 1, device group II, device category 2G, explosion group II B. The compact and effective gas boosters with two air drive and two high pressure sections are available in different pressure ratios. By combining two different pressure stages and the effective cooling of both stages, even high compression ratios can be realised with just one gas booster and low available air drive pressure.

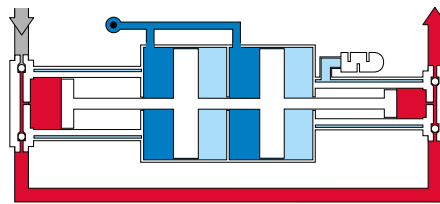

Working principle DLE 15-30-2

### DLE...-...- 2

- » Two stage
- » With two air drive sections
- » Working pressure up to 2100 bar (30000 psi)
- » Formula for gas outlet pressure: see table
- » Material: compressor head, high pressure cylinders and high-pressure pistons as well as fittings made of aluminum (Stages 2 and 5) or stainless steel (Stages 15, 30 and 75); PTFE seals.
- » All gas boosters are equipped with media separation (Z) and flushing connection (SFP) (Z-connections, SFP = G 1/8 ").
- » Active cooling from DLE 2-5-2, stage 5 included as standard
- » Suitable for air drive pressures (p<sub>L</sub>) from 1 to 10 bar (14.5 to 145 psi)

### Options for DLE... -...-2

- » Special sealing options for high and low temperature applications (-40 up to +120 °C)
- » EXIIC-Option (Device group IIC)
- » FEC-Option for dry compressed air or nitrogen drive
- » C-Option for CO<sub>2</sub> applications
- » S-Option for O<sub>2</sub> applications
- » H2-Option for H<sub>2</sub> applications
- » ZK option: intercooler for gas cooling after the first compression stage
- » Various connections for inlet / outlet (BSP, NPT, UNF)

Type	Pressure ratio $i_1 / i_2^*$	Stroke volume**		max. working pressure p <sub>B</sub> ***		min. gas inlet pressure p <sub>Amin</sub>		max. gas inlet pressure p <sub>Amax</sub>
		[cm <sup>3</sup> ]	[in <sup>3</sup> ]	[bar]	[psi]	[bar]	[psi]	
DLE 2-5-2	1:4 / 1:10	922	56,3	100	1450	0	0	1,6*p <sub>L</sub>
DLE 5-15-2	1:10 / 1:30	373	22,8	300	4350	2	29	3,2*p <sub>L</sub>
DLE 5-30-2	1:10 / 1:60	373	22,8	600	8700	2	29	1*p <sub>L</sub>
DLE 15-30-2	1:30 / 1:60	122	7,4	600	8700	7	102	15*p <sub>L</sub>
DLE 15-75-2	1:30 / 1:150	122	7,4	1500	21750	7	102	5*p <sub>L</sub>
DLE 30-75-2	1:60 / 1:150	60	3,7	1500	21750	15	218	24*p <sub>L</sub>
DLE 30-75-2-25	1:60 / 1:150	60	3,7	1800	25000	15	218	24*p <sub>L</sub>
DLE 30-75-2-30	1:60 / 1:150	60	3,7	2100	30000	15	218	24*p <sub>L</sub>

\* Pressure ratio of air drive piston surface area to output piston surface area

\*\* Calculated stroke volume

\*\*\* Maximum permissible static working pressure

p<sub>A</sub> = Gas inlet pressure

p<sub>B</sub> = Working pressure

p<sub>L</sub> = Air drive pressure

i = Pressure ratio



DLE 15-30-2

**Accessories:**

- » Air control unit
- » Pressure switches
- » Cooler
- » Spare part sets
- » Valves, Fittings, Tubing
- » Gas booster stations ready for connection according to specification

Further options and accessories on request.

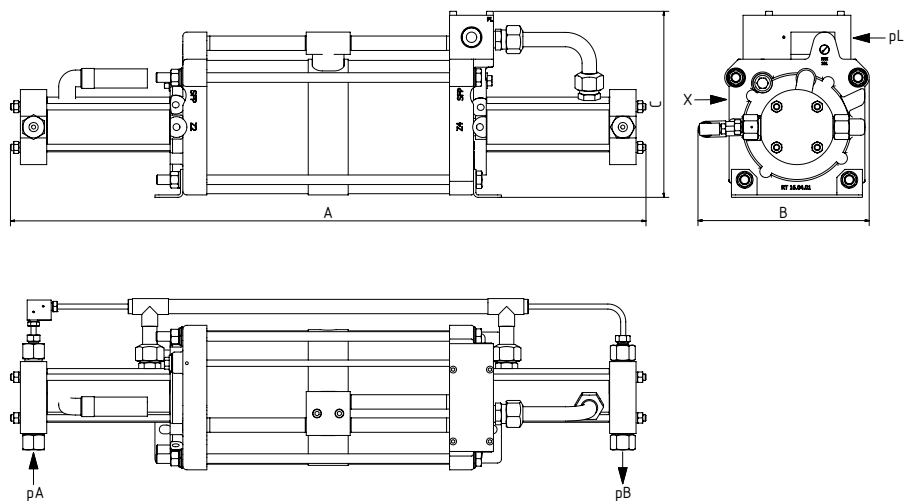

Type	Formula for gas outlet pressure $p_B$	Connections ["]			Dimensions [mm]			Weight [kg]
		Luft	Einlass A	Auslass B	A	B	C	
DLE 2-5-2	$p_B = 10 \cdot p_L + 10/4 \cdot p_A$	G 3/4	G 1/2	G 1/2	788	235	233	20
DLE 5-15-2	$p_B = 30 \cdot p_L + 30/10 \cdot p_A$	G 3/4	G 1/2	G 1/4	791	257	233	27,3
DLE 5-30-2	$p_B = 60 \cdot p_L + 60/10 \cdot p_A$	G 3/4	G 1/2	G 1/4	791	257	233	27,2
DLE 15-30-2	$p_B = 60 \cdot p_L + 60/30 \cdot p_A$	G 3/4	G 1/4	G 1/4	796	215	233	25,4
DLE 15-75-2	$p_B = 150 \cdot p_L + 150/30 \cdot p_A$	G 3/4	G 1/4	G 1/4	799	215	233	16,3
DLE 30-75-2	$p_B = 150 \cdot p_L + 150/60 \cdot p_A$	G 3/4	G 1/4	G 1/4	799	215	233	25,4
DLE 30-75-2-25	$p_B = 150 \cdot p_L + 150/60 \cdot p_A$	G 3/4	G 1/4	9-16-18UNF (4H)	822	272	233	25,4
DLE 30-75-2-30	$p_B = 150 \cdot p_L + 150/60 \cdot p_A$	G 3/4	G 1/4	9-16-18UNF (4H)	822	272	233	25,4

ⓘ High pressure gas booster with outlet connections type BSPP or NPT are suitable for outlet pressures of up to 1050 bar (15000 psi). For higher outlet pressures, the gas boosters must be ordered with high pressure connections according to the required pressure range.

# Gas booster Series

## » DLE...-...-3 two stage, 3 air drive sections

Maximator gas boosters in two stage design with 2 air drive pistons are suitable for the use in hazardous areas of Zone 1, device group II, device category 2G, explosion group II B. The ultra-high pressure gas booster with three air drive and two high pressure sections is developed for the compression of technical gases up to 2400 bar (36000 psi).

### DLE ...-...-3

- » Two stage
- » With three air drive sections
- » Working pressure up to 2400 bar (36000 psi)
- » Formula for gas outlet pressure: see table
- » Material: compressor head, high pressure cylinders and high-pressure pistons as well as fittings made of stainless steel; PTFE seals.
- » All gas boosters are equipped with media separation (Z) and flushing connection (SFP) (Z-connections, SFP = G 1/8 ").
- » Active cooling included as standard
- » Suitable for air drive pressures ( $p_L$ ) from 1 to 10 bar (14.5 to 145 psi)

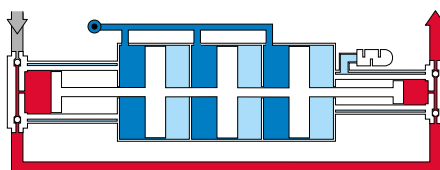

Working principle DLE 30-75-3

### Options for DLE... -...-3

- » Special sealing options for high and low temperature applications (-40 up to +120 °C)
- » EXIIC-Option (Device group IIC)
- » FEC-Option for dry compressed air or nitrogen drive
- » ZK option: intercooler for gas cooling after the first compression stage

Type	Pressure ratio $i_1 / i_2^*$	Stroke volume**		max. working pressure $p_b^{***}$		min. gas inlet pressure $p_{Amin}$		max. gas inlet pressure $p_{Amax}$
		[cm <sup>3</sup> ]	[in <sup>3</sup> ]	[bar]	[psi]	[bar]	[psi]	
DLE 30-75-3-36	1:90 / 1:225	60	3,7	2400	36000	30	435	$30 \cdot p_L$

\* Pressure ratio of air drive piston surface area to output piston surface area

\*\* Calculated stroke volume

\*\*\* Maximum permissible static working pressure

$p_A$  = Gas inlet pressure

$p_b$  = Working pressure

$p_L$  = Air drive pressure

$i$  = Pressure ratio





DLE 30-75-3 with intercooler

**Accessories:**

- » Air control unit
- » Pressure switches
- » Spare part sets
- » Valves, Fittings, Tubing
- » Gas booster stations ready for connection according to specification

Further options and accessories on request.

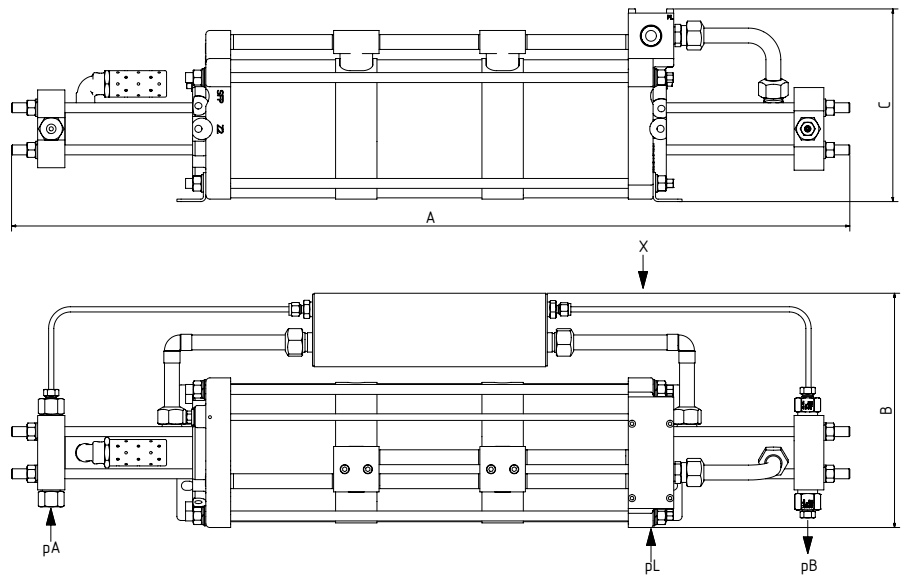

Type	Formula for gas outlet pressure $p_B$	Connections ["]			Dimensions [mm]			Weight [kg]
		Drive air	Inlet A	Outlet B	A	B	C	
DLE 30-75-3-36	$p_B = 225 \cdot p_L + 225/90 \cdot p_A$	G 3/4	G 1/4	9-16-18UNF (4H)	1014	283	233	39,4

# Gas booster Series

## » 8DLE... 8"- Drive

Maximator gas boosters in single stage, double or quadruple acting design with one or two air drive pistons are suitable for the use in hazardous areas of Zone 1, device group II, device category 2G, explosion group II B. The effective gas boosters with 200 mm (8") drive pistons are available in different pressure ratios and specially designed for high, continuous delivery rates.

### 8DLE...

- » Double or quadruple acting
- » Single stage
- » With one or air drive section
- » Working pressure up to 300 bar (4350 psi)
- » Formula for gas outlet pressure:

$$p_B = i * p_L + p_A$$

- » Material: compressor head, high pressure cylinders and high-pressure pistons as well as fittings made of aluminum (8DLE 3/ 8DLE 6) or stainless steel (8DLE 1,65); PTFE seals.

- » All gas boosters of the 8DLE Series are equipped with media separation (Z) (Z-connections = G 1/8 ").

- » Suitable for air drive pressures ( $p_L$ ) from 1 to 10 bar (14.5 to 145 psi)

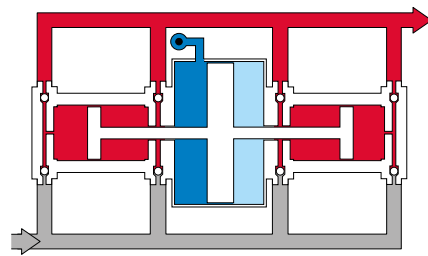

Working principle 8DLE 1,65

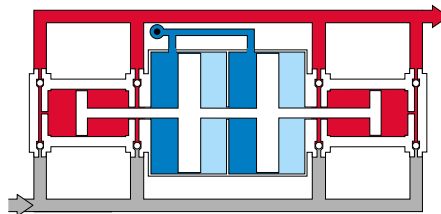

Working principle 8DLE 3

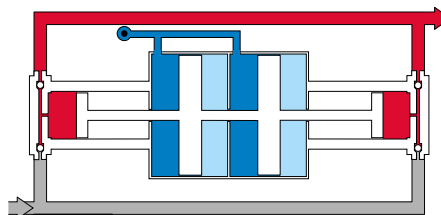

Working principle 8DLE 6

### Options for 8DLE...

- » Special sealing options for high and low temperature applications (-40 up to +120 °C)
- » EXIIC-Option (Device group IIC)
- » ASS-Option: Air drive section made of stainless steel
- » HMR-Option: High pressure section made of stainless steel in accordance with NACE MR0175 oder MR0103
- » Various connections for inlet / outlet (BSP, NPT, 1/2" welding flange)

Type	Pressure ratio $i^*$	Stroke volume**		max. working pressure $p_B^{***}$		min. gas inlet pressure $p_A$		max. gas inlet pressure $p_A$	
		[cm <sup>3</sup> ]	[in <sup>3</sup> ]	[bar]	[psi]	[bar]	[psi]	[bar]	[psi]
8DLE 1,65	1:1,65	4100	250,2	300	4350	0	0	300	4350
8DLE 3	1:3	4100	250,2	40	580	0	0	40	580
8DLE 6	1:6	2050	125,1	40	580	0	0	40	580

\* Pressure ratio of air drive piston surface area to output piston surface area

\*\* Calculated stroke volume

\*\*\* Maximum permissible static working pressure

$p_A$  = Gas inlet pressure

$p_B$  = Working pressure

$p_L$  = Air drive pressure

$i$  = Pressure ratio

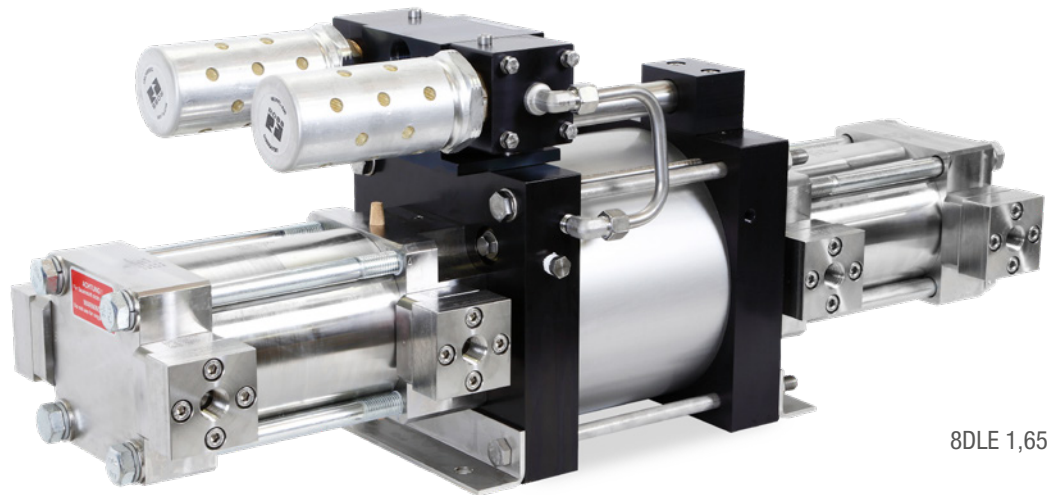

8DLE 1,65

**Accessories:**

- » Air control unit
- » Pressure switches
- » Cooler
- » Spare part sets
- » Valves, Fittings, Tubing
- » Gas booster stations ready for connection according to specification

Further options and accessories on request.

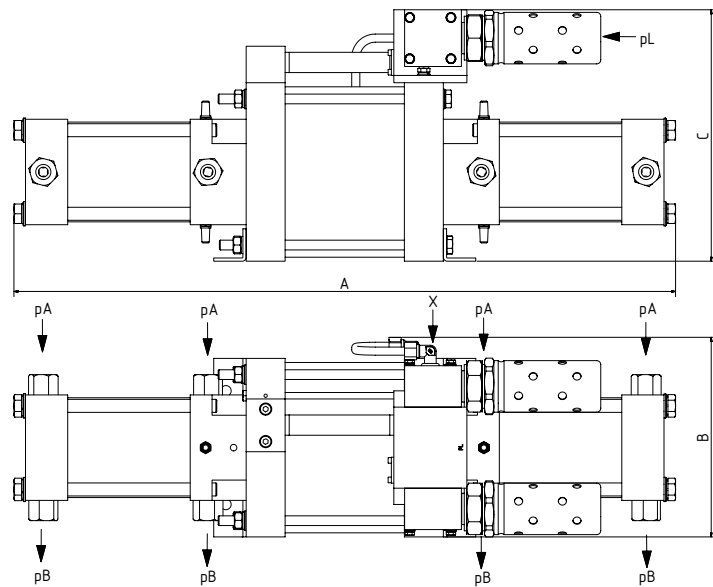

Type	Connections ["]			Dimensions [mm]			Weight [kg]
	Luft	Einlass A	Auslass B	A	B	C	
8DLE 1,65	G 3/4	G 1/2	G 1/2	815	246	310	70
8DLE 3	G 3/4	G 1/2	G 1/2	978	249	310	52
8DLE 6	G 3/4	G 1/2	G 1/2	978	249	310	52

## » Flow capacity

The flow capacity of gas boosters mainly depends on the air drive pressure and, in the case of double-acting or two-stage devices, also on the gas inlet pressure. Detailed performance curves can be found in the data sheets for the various gas booster types at [www.maximator.de](http://www.maximator.de). The flow capacity tables shown here contain rounded values and are used to compare the gas booster types. Please consult Maximator to determine the expected performance characteristics for a specific application.

Type	$p_L = 6 \text{ bar}$			Type	$p_L = 6 \text{ bar}$			Type	$p_L = 6 \text{ bar}$		
	$p_A$ [bar]	$p_B$ [bar]	Q [l <sub>n</sub> /min]		$p_A$ [bar]	$p_B$ [bar]	Q [l <sub>n</sub> /min]		$p_A$ [bar]	$p_B$ [bar]	Q [l <sub>n</sub> /min]
DLE 2-1	2	5	120	8DLE 6	6	40	230	DLE 15-1	34	40	240
DLE 2-1	2	8	85	DLE 5-15-2	6	70	75	DLE 15	34	40	500
DLE 5-30	2	40	55	DLE 5-15	6	70	100	DLE 15-1	34	70	130
DLE 5-30	2	120	40	DLE 5-15-2	6	120	60	DLE 15-1-2	34	70	213
DLE 5-30	3	40	75	DLE 5-30-2	6	120	75	DLE 15-2	34	70	390
DLE 5-30	3	120	55	DLE 5-30-2	6	210	65	DLE 15	34	70	400
DLE 2-1	4	5	200	DLE 5-1	10	15	180	DLE 15-30-2	34	120	130
DLE 2	4	5	400	DLE 5-1-2	10	15	210	DLE 15-1-2	34	120	150
DLE 2-1	4	8	145	DLE 5-2	10	15	390	DLE 15-2	34	120	300
DLE 2-5	4	8	180	DLE 5	10	15	405	DLE 30-75	34	210	115
DLE 2-1-2	4	8	210	DLE 5-1	10	25	80	DLE 15-30-2	34	350	60
DLE 2	4	8	340	DLE 5	10	25	300	DLE 30-75-2	34	350	60
8DLE 3	4	8	1060	DLE 5-1-2	10	40	140	DLE 30-75	34	350	90
DLE 5-1	4	15	80	DLE 5-2	10	40	275	DLE 30-75-2	34	600	50
DLE 5-1-2	4	15	95	DLE 5-15-2	10	70	120	8DLE 1,65	50	53	9900
DLE 2-5-2	4	15	125	DLE 5-15-2	10	120	105	8DLE 1,65	50	56	7540
DLE 2-1-2	4	15	155	DLE 15-75	10	210	70	DLE 30-1	50	70	180
DLE 5	4	15	160	DLE 15-75	10	350	45	DLE 30	50	70	355
DLE 5-2	4	15	165	DLE 15-1	15	40	110	DLE 30-1	50	120	130
DLE 2-2	4	15	300	DLE 15	15	40	200	DLE 30-1-2	50	120	170
8DLE 6	4	15	530	DLE 15-1	15	70	60	DLE 15-30-2	50	120	195
8DLE 3	4	15	840	DLE 15-1-2	15	70	95	DLE 30-2	50	120	285
DLE 5-1	4	25	35	DLE 15-30	15	70	105	DLE 30	50	120	290
DLE 2-2	4	25	85	DLE 15	15	70	130	DLE 30-1-2	50	210	140
DLE 5	4	25	90	DLE 15-2	15	70	165	DLE 30-2	50	210	225
DLE 2-5	4	25	175	DLE 15-1-2	15	120	65	DLE 15-30-2	50	350	115
DLE 5-1-2	4	40	65	DLE 15-30	15	120	90	DLE 75-1	75	210	100
DLE 5-15	4	40	90	DLE 15-2	15	120	115	DLE 75	75	210	205
8DLE 6	4	40	100	DLE 15-75	15	210	100	DLE 75-1	75	350	55
DLE 5-2	4	40	105	DLE 15-75-2	15	350	55	DLE 75-1-2	75	350	100
DLE 2-5-2	4	40	105	DLE 15-75	15	350	75	DLE 75	75	350	135
DLE 5-15	4	70	65	DLE 15-75-2	15	600	45	DLE 30-75-2	75	350	140
DLE 5-30-2	4	120	55	8DLE 1,65	22	25	4480	DLE 75-2	75	350	155
DLE 5-30-2	4	210	45	8DLE 1,65	22	30	1995	DLE 75-1-2	75	600	70
DLE 2-5	6	8	250	DLE 30-1	22	70	80	DLE 75-2	75	600	110
DLE 2-1-2	6	8	300	DLE 30	22	70	145	DLE 30-75-2	75	600	120
DLE 2	6	8	535	DLE 15-30	22	70	155	DLE 75-1	115	210	155
DLE 2-1-2	6	15	220	DLE 30-1	22	120	55	DLE 75	115	210	330
DLE 2	6	15	220	DLE 30-1-2	22	120	80	DLE 75-1	115	350	85
DLE 2-2	6	15	460	DLE 30	22	120	105	DLE 75-1-2	115	350	150
8DLE 6	6	15	750	DLE 30-2	22	120	120	DLE 75	115	350	240
8DLE 3	6	15	1300	DLE 15-30	22	120	140	DLE 75-2	115	350	245
DLE 2-5-2	6	25	180	DLE 30-1-2	22	210	60	DLE 75-1-2	115	600	105
DLE 2-2	6	25	190	DLE 30-75	22	210	70	DLE 75-2	115	600	180
8DLE 3	6	25	195	DLE 30-2	22	210	90	DLE 30-75-3	120	1000	120
DLE 2-5	6	25	245	DLE 30-75	22	350	50	DLE 30-75-3	120	1600	15
DLE 5-15	6	40	125	DLE 15-75-2	22	350	80	DLE 30-75-3	170	1000	185
DLE 2-5-2	6	40	160	DLE 15-75-2	22	600	70	DLE 30-75-3	170	1600	60

$p_L$  = Air drive pressure  
 $p_A$  = Gas inlet pressure

$p_B$  = Working pressure  
 Q = Flow capacity at working point

# » Gas booster selection

The selection of a suitable Maximator gas booster takes various criteria into account, which essentially depend on the type of application and the specified application parameters.

For the selection based on a process, such as the testing of components in a defined time with a gas cylinder supply (i.e. a variable gas inlet and gas outlet pressure) we recommend consulting Maximator or its global partners for the correct selection of the suitable gas booster or gas booster combination.

However, if a specific operating point is defined for an application - i.e. continuous flow capacity at a defined gas outlet pressure and a constant gas inlet pressure - the selection can be made conveniently using the performance parameters from this catalog.

Depending on the general conditions of the application, it is advisable to consider further criteria (such as the installation space or the available air drive volume flow) when making the selection.

## Gas booster selection for a defined operating point

An operating point indicates which volume flow  $Q$  a gas booster should generate at a required gas outlet pressure  $p_B$  with a specific gas inlet pressure  $p_A$  and an air drive pressure  $p_L$ .

The operating point for a gas booster is defined by:

1. Air drive pressure  $p_L$
2. Gas inlet pressure  $p_A$
3. Gas outlet pressure  $p_B$  (working pressure)
4. Flow capacity  $Q$

The operating point enables different gas-boosters to be compared with each another despite their different design and working principle, and to be selected according to the requirements of the application.

First, the process media and the associated requirements for the operation have to be

checked. An overview of the most common gases is given in the process fluids table, on page 31.

The next criteria is the required pressure ratio. By dividing the required gas outlet pressure with the available air drive pressure, we obtain the minimum required pressure ratio  $i$ . This means that the selection can be limited to a few options.

$$i = \frac{\text{Gas outlet pressure } p_B}{\text{Air drive pressure } p_L}$$

Another criteria is the compression ratio, which describes the ratio of gas outlet pressure to gas inlet pressure.

$$\varepsilon = \frac{\text{Gas outlet pressure } p_B}{\text{Gas inlet pressure } p_A}$$

The compression ratio is required to calculate the temperature increase during gas compression. The higher the compression ratio, the higher the temperature of the outlet gas during compression. It must be ensured that the maximum compression ratio of a gas booster is not exceeded. The product data are compiled in the "Overview technical features and connections" table, on page 30.

## Example of gas booster selection

In the following, a selection for a specific operating point is carried out using a practical example. The selection is based on the following application parameters:

Process gas:	Nitrogen ( $N_2$ )
Gas inlet pressure $p_A$ :	25 bar
Gas outlet pressure $p_B$ :	150 bar
Air drive pressure $p_L$ :	6 bar
Flow capacity $Q$ :	min. 60 l <sub>n</sub> /min

### 1. Process gas

The process gas for the sample selection is nitrogen. According to the process fluids table, all DLE models are suitable for nitrogen and no further restrictions regarding ventilation or

purging (inerting) have to be considered.

### 2. Min. pressure ratio $i$

If the process parameters are entered in the formula for calculating the pressure ratio, the result is:

$$150 \text{ bar} / 6 \text{ bar} = 25 \rightarrow i > \mathbf{1:25}$$

This means that all gas boosters with a pressure ratio of  $i > 1:25$  are basically suitable. The devices with the next higher pressure ratio should preferably be selected - in this case all devices with  $i = 1:30$ .

### 3. Compression ratio

If the process parameters are entered in the formula for calculating the compression ratio, the result is:

$$150 \text{ bar} / 25 \text{ bar} = 6 \rightarrow \varepsilon = \mathbf{1:6}$$

This means that all gas boosters with a maximum permissible compression ratio of  $\varepsilon > 1:6$  are suitable.

On the basis of the calculated pressure and compression ratios, the following gas boosters can be considered:

- DLE 15-1-2
- DLE 15-2
- DLE 30-1
- DLE 30

Taking into account the required volume flow, the DLE 30 delivers a sufficiently high flow capacity based on the process parameters for this example.

## » Overview of technical features and connections

Type	Stroke volume [cm <sup>3</sup> ]	max. working pressure p <sub>B</sub> [bar]	max. compression ratio ε	pressure ratio i	max. operating temperature T [°C]	gas inlet pressure		Connections		Recommended pipe internal diameter		
						min. p <sub>A</sub> [bar]	max. p <sub>A</sub> [bar]	Inlet A	Outlet B	p <sub>L</sub> [mm]	p <sub>A</sub> [mm]	p <sub>B</sub> [mm]
DLE 2-1	922	20	1:10	1:2	60	0	20	G 1/2	G 1/2	19	13	13
DLE 5-1	373	50	1:15	1:5	60	2	50	G 1/2	G 1/2	19	13	13
DLE 15-1	122	150	1:20	1:15	100	7	150	G 1/4	G 1/4	19	6	4
DLE 30-1	60	300	1:20	1:30	100	15	300	G 1/4	G 1/4	19	6	4
DLE 75-1	25	750	1:20	1:75	100	35	750	G 1/4	G 1/4	19	6	4
DLE 2-1-2	922	40	1:10	1:4	60	0	40	G 1/2	G 1/2	19	13	13
DLE 5-1-2	373	100	1:15	1:10	60	4	100	G 1/2	G 1/2	19	13	13
DLE 15-1-2	122	300	1:20	1:30	100	10	300	G 1/4	G 1/4	19	6	4
DLE 30-1-2	60	600	1:20	1:60	100	20	600	G 1/4	G 1/4	19	6	4
DLE 75-1-2	25	1500	1:20	1:150	100	45	1500	G 1/4	G 1/4	19	6	4
DLE 2	1844	40	1:10	1:2	60	0	40	G 1/2	G 1/2	19	13	13
DLE 5	746	100	1:15	1:5	60	2	100	G 1/2	G 1/2	19	13	13
DLE 15	244	300	1:20	1:15	100	7	300	G 1/4	G 1/4	19	6	4
DLE 30	120	600	1:20	1:30	100	15	600	G 1/4	G 1/4	19	6	4
DLE 75	50	1500	1:20	1:75	100	35	1500	G 1/4	G 1/4	19	6	4
DLE 2-2	1844	40	1:10	1:4	60	0	40	G 1/2	G 1/2	19	13	13
DLE 5-2	746	100	1:15	1:10	60	4	100	G 1/2	G 1/2	19	13	13
DLE 15-2	244	300	1:20	1:30	100	10	300	G 1/4	G 1/4	19	6	4
DLE 30-2	120	600	1:20	1:60	100	20	600	G 1/4	G 1/4	19	6	4
DLE 75-2	50	1500	1:20	1:150	100	45	1500	G 1/4	G 1/4	19	6	4
DLE 2-5	922	70	1:25	1:2/1:5	60	0	0,8 x p <sub>L</sub>	G 1/2	G 1/2	19	13	13
DLE 5-15	373	198	1:45	1:5/1:15	100	2	1,6 x p <sub>L</sub>	G 1/2	G 1/4	19	13	4
DLE 5-30	373	330	1:90	1:5/1:30	100	2	0,5 x p <sub>L</sub>	G 1/2	G 1/4	19	13	4
DLE 15-30	122	450	1:40	1:15/1:30	100	7	7,5 x p <sub>L</sub>	G 1/4	G 1/4	19	6	4
DLE 15-75	122	875	1:100	1:15/1:75	100	7	2,5 x p <sub>L</sub>	G 1/4	G 1/4	19	6	4
DLE 30-75	60	1050	1:50	1:30/1:75	100	15	12 x p <sub>L</sub>	G 1/4	G 1/4	19	6	4
DLE 2-5-2	922	100	1:25	1:4/1:10	60	0	1,6 x p <sub>L</sub>	G 1/2	G 1/2	19	13	13
DLE 5-15-2	373	300	1:45	1:10/1:30	100	2	3,2 x p <sub>L</sub>	G 1/2	G 1/4	19	13	4
DLE 5-30-2	373	600	1:90	1:10/1:60	100	2	1 x p <sub>L</sub>	G 1/2	G 1/4	19	13	4
DLE 15-30-2	122	600	1:40	1:30/1:60	100	7	15 x p <sub>L</sub>	G 1/4	G 1/4	19	6	4
DLE 15-75-2	122	1500	1:100	1:30/1:150	100	7	5 x p <sub>L</sub>	G 1/4	G 1/4	19	6	4
DLE 30-75-2	60	1500	1:50	1:60/1:150	100	15	24 x p <sub>L</sub>	G 1/4	G 1/4	19	6	4
DLE 30-75-3	60	2400	1:50	1:90/1:225	100	30	30 x p <sub>L</sub>	G 1/4	4H	19	6	4
8DLE 1,65	4100	100	1:10	1:1,65	100	0	100	G 1/2	G 1/2	19	13	13
8DLE 3	4100	40	1:15	1:3,3	60	0	40	G 1/2	G 1/2	19	13	13
8DLE 6	2050	40	1:15	1:6,6	60	0	40	G 1/2	G 1/2	19	13	13

p<sub>L</sub> = Air drive pressure  
p<sub>A</sub> = Gas inlet pressure

p<sub>B</sub> = Working pressure  
i = Pressure ratio

ε = Compression ratio (ε = p<sub>B</sub>/p<sub>A</sub>)

## » Process fluids

Maximator gas boosters are suitable for compressing a wide variety of gases. Special versions and options are available with which the gas boosters can be configured for special gases. The most common fluids and the gas booster designs recommended by Maximator are listed in the following table.

In general the process media must be compatible with the wetted gas booster materials. Please contact us at [components@maximator.de](mailto:components@maximator.de) for questions around your application or gases not mentioned below.

Process fluid (gaseous)	Formula symbol	Gas booster type	Recommendations for compressing the process fluid
Argon	Ar	all models	Well-ventilated room
N-Butane	C <sub>4</sub> H <sub>10</sub>	all models	Fit piping to and flush SFP* (special flushing port) and leak detection holes.
Carbon monoxide	CO	DLE xxx-C	Fit piping to and flush SFP* (special flushing port) and leak detection holes.
Carbon dioxide	CO <sub>2</sub>	DLE xxx-C	Well-ventilated room
Ethane	C <sub>2</sub> H <sub>6</sub>	all models	Fit piping to and flush SFP* (special flushing port) and leak detection holes.
Ethylene	C <sub>2</sub> H <sub>4</sub>	all models	Fit piping to and flush SFP* (special flushing port) and leak detection holes.
Freon (F-12)	CCL <sub>2</sub> F <sub>2</sub>	DLE xxx-CR	Fit piping to and flush SFP* (special flushing port) and leak detection holes.
Helium	He	all models	Well-ventilated room
Hydrogen	H <sub>2</sub>	DLE xxx-H2	Fit piping to and flush SFP* (special flushing port) and leak detection holes. max. compression ratio 1:4
Methane	CH <sub>4</sub>	all models	Fit piping to and flush SFP* (special flushing port) and leak detection holes.
Sour gas (natural gas with proportion of hydrogen sulphide)		DLE xxx-HMR	Fit piping to and flush SFP* (special flushing port) and leak detection holes.
Propane	C <sub>3</sub> H <sub>8</sub>	all models	Fit piping to and flush SFP* (special flushing port) and leak detection holes.
Nitrogen	N <sub>2</sub>	all models	Well-ventilated room
Nitrous oxide	N <sub>2</sub> O	DLE xxx-S	Fit piping to and flush SFP* (special flushing port) and leak detection holes.
Oxygen	O <sub>2</sub>	DLE xxx-S	Fit piping to leak detection holes, oil-free and grease-free drive air, max. compression ratio 1:4** max. operating pressure 350 bar
Sulphur hexafluoride	SF <sub>6</sub>	DLE xxx-CR	Fit piping to and flush SFP* (special flushing port) and leak detection holes.
Syngas (synthesis gas)		DLE xxx-H2	Fit piping to and flush SFP* (special flushing port) and leak detection holes. Please contact us for the product selection.
Xenon	XE	all models	Well-ventilated room

\* Flushing port for any high-pressure leaks occurring

\*\* taking into account the ignition temperature of greases minus a safety reserve of 80°C

# » Compact-Booster Series

The Compact-Booster Series is designed for users who need to compress oxygen up to 300 bar in the most easy and effective way. Professional divers are using the boosters of the Compact-Booster Series to fill oxygen bottles or to mix gases for the technical diving as well as fire and emergency stations are committed to the quality of these compact boosters.

The compact boosters are driven with compressed air up to 10 bar. Alternatively, the compact boosters can also be driven from a gas bottle or even by manual operation. In short, the compact boosters are ideal for use in any environment or work area. They are lightweight and flexible. They can be mounted in a dive boat or permanently installed in a fire station.

## Compact-Booster Series

There are three models in the Compact-Booster series which offers the optimal solution for each application. Even at low gas inlet pressure the required working pressure is generated quickly. This will ensure an optimum use of your oxygen bottles.

Installing the ROB is done with a few simple steps leading to both space and time saving.

- » Single or double acting
- » one or two-stage
- » With one air drive section
- » Suitable for oxygen or nitrogen applications
- » Working pressure up to 300 bar (4350 psi)
- » Suitable for air drive pressures ( $p_L$ ) from 1 to 10 bar (14.5 to 145 psi)

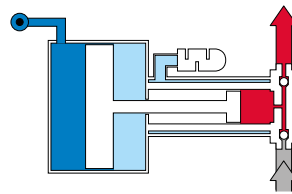

Working principle ROB 22

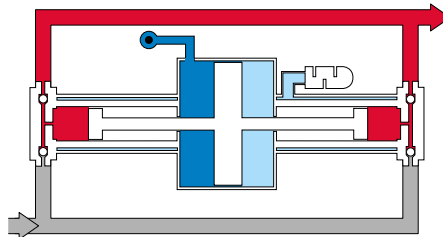

Working principle ROB/RNB 32D

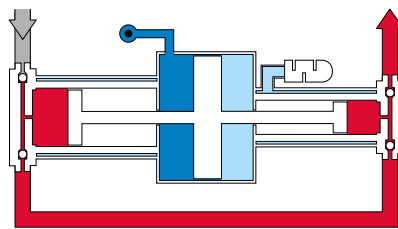

Working principle ROB/RNB 8-37

### Options for Compact-Booster Series

- » HL-Option: Hand lever attachment for manual operation of the booster (only available for ROB 22)

Type	Pressure ratio $i^*$	Process gas	max. working pressure $p_b^{**}$		min. gas inlet pressure $p_A$		max. gas inlet pressure $p_A$	
			[bar]	[psi]	[bar]	[psi]	[bar]	[psi]
ROB 22 (HL)	1:28	Oxygen	280	4060	50	725	280	4060
ROB 32D	1:32	Oxygen	300	4350	50	725	300	4350
ROB 8-37	1:8/1:37	Oxygen	300	4350	10	145	20	290
RNB 32 D	1:32	Nitrogen	300	4350	50	725	300	4350
RNB 8-37	1:8/1:37	Nitrogen	300	4350	10	145	20	290

\* Pressure ratio of air drive piston surface area to output piston surface area

\*\* Maximum permissible static working pressure

\*\*\* The flow is depending on the available air drive and inlet pressure

$p_A$  = Gas inlet pressure

$p_b$  = Working pressure

$p_L$  = Air drive pressure

$i$  = Pressure ratio





**Accessories:**

- » Air control unit
- » Pressure switches
- » Spare part sets
- » Valves, Fittings, Tubing
- » Gas booster stations ready for connection according to specification

Further options and accessories on request.

Average flow*** [l <sub>n</sub> /min]	Connections ["]			Dimensions [mm]			Weight [kg]
	Drive air	Inlet A	Outlet B	A	B	C	
180	G 3/8	G 1/4	G 1/4	200	116	116	3,7
280	G 3/8	G 1/4	G 1/4	286	122	110	5,4
30	G 3/8	G 1/4	G 1/4	200	116	116	7
280	G 3/8	G 1/4	G 1/4	286	122	110	5,4
30	G 3/8	G 1/4	G 1/4	200	116	116	7

# Additional products

## » Gas booster stations

### Customized system solutions for gas compression and gas recovery

Maximator booster stations for nitrogen, oxygen, hydrogen or a wide variety of other gases are complete booster stations ready for connection which are provided for generating operating pressures up to 2400 bar.

Based on the know-how of a manufacturer of high pressure gas boosters, Maximator produces individual system solutions - both as completed or partly completed machines - for all types of testing, filling, production and pressure generating applications. Gas recovery systems enable the efficient use of gases such as helium, xenon or other relatively expensive gases and thus offer considerable saving potential.

We analyze the compression task in detail, design the system and select the suitable gas boosters. All required components, such as pressure switches, pneumatically or electrically operated directional valves, adapters, quick-release couplings, pressure filters, gas accumulators, high-pressure hoses as well as shut-off and control valves are expertly selected and matched to the requirements of the compression task.

Our sales engineers in the technical offices and our partners worldwide will be glad to advise you and recommend the optimal solution for every application.



4-stage gas booster station in cabinet design with high pressure gas storage and regulation



Mobile gas booster station in a stainless steel protection frame with pressure regulation and measuring connections



Nitrogen charging station for charging of hydraulic accumulators for gas bottle assembly with pressure switch



PLC controlled gas booster station in frame design with high pressure storage and gas cooling

# » Electro-hydraulic gas booster

## » MAX-Compression System

### Electro-hydraulic gas booster type EHB

The new generation of EHB type gas booster has been developed for the effective compression of gases in applications with high flow capacities. Thanks to the servo-hydraulic drive concept, the gas boosters of the EHB series achieve a new level of efficiency, delivery capacity and compactness compared to conventional hydraulic compressor

systems. The drive unit is a closed, hydraulic system and consists of a cylinder unit with an attached, variable-speed motor-pump group and a drive control unit.

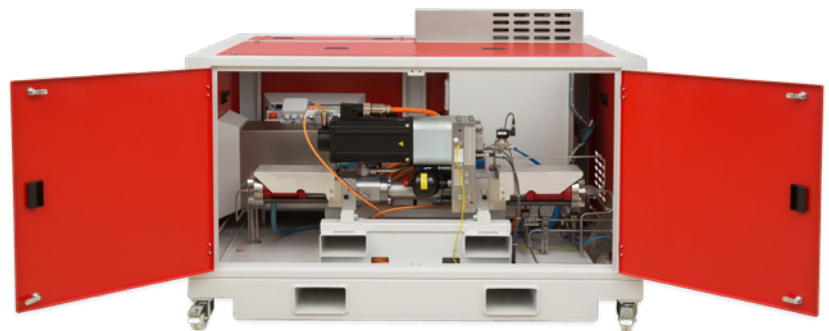

- High pressure applications up to 1000 bar
- servo-hydraulic drive concept (max. force of 75 kN)
- Very good energy efficiency with savings of up to 40% (compared to conventional hydraulic compressors)

- Closed hydraulic system with independent control
- Double acting, with two high pressure sections
- Internal cooling for high pressure section (gas) and drive section (oil)

### MAX-Compression - the new generation of hydrogen compressors with ASX technology

The patented MAX-Compression design is a 2-stage, fluidically driven highpressure piston compressor that compresses hydrogen from 24 bar to maximum 1000 bar. It is equipped with the ASX function (automatic seal exchange), which ensures an automatic seal change of the hydrogen high pressure seal.

This automatic change reduces unplanned downtime to a minimum. The seal change itself takes about 3 minutes per pressure converter. The system is a dry-running compressor system, so there is no possibility of contamination of the hydrogen to be refueled or the environment in the event of leaks..

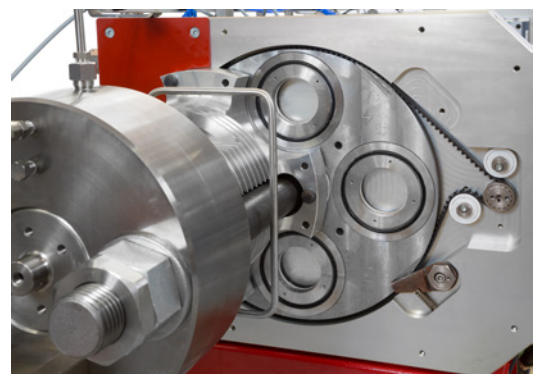
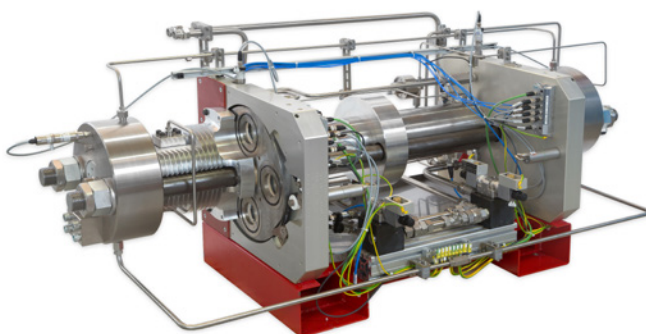

- Double acting hydrogen compressor
- Pressure range 24 - 1000 bar
- pressure ratio up to 1:40

- max. compressor capacity 100 kg/h hydrogen
- hydrogen quality: according to SAE J2719
- Average Energy Consumption approx. 1 kWh/kg H<sub>2</sub>

# » Air Amplifier Type PLV

## Air amplifier – the concept

PLV series Air Amplifiers are suitable for the compression of pressurised air or nitrogen. The units are capable of increasing low system pressures of e.g. 4 bar or 6 bar to the intended final pressures. They are ideally suited for local pressurisation or point of use applications requiring higher pressures than is available in a factory shop air system.

Typical areas of application for the Maximator air amplifier type PLV can be found in the area of Burner cleaning (Purging of impurities with 16-bar pressure shocks), automotive sector (Filling of tyres with 16-bar pressure), varnishing industry (Cleaning of varnishing systems ) or even in general mechanical engineering for the compressed air supply for the actuation of valves or pneumatic cylinders.

## Air Amplifier – system solutions

All Air Amplifiers can be supplied with an air control unit comprising a filter, pressure regulator with pressure gauge and an air shut-off valve. The desired operating pressure can be preset with the air control unit in correspondence with the different pressure ratios. In addition, our system solutions offer high pressure gas storage and optional pressure regulation. Please choose between a standard air amplifier station or a customised solution.

## Function

The compressed air from the standard air system is compressed to the desired higher final pressure. This is a simple, safe and economic mode of operation.

Thus, expenditures for an in-house high-pressure system or a separate decentralised compressor plant can be saved.

The operating principle of a Maximator air amplifier is similar to an oscillating pressure intensifier. They are used to compress compressed air or nitrogen to higher pressures and are operated with a compressed air supply at up to 10 bar.

The air amplifiers of the PLV series work according to two functional principles.

All air amplifiers with a pressure ratio greater than 1:2 compress compressed air or nitrogen according to the same principle as the DLE type gas boosters (page 4).

All air amplifiers with a pressure ratio of 1:2 work according to the following principle: Each air amplifier is equipped with two pistons of the same size that are connected with a piston rod.

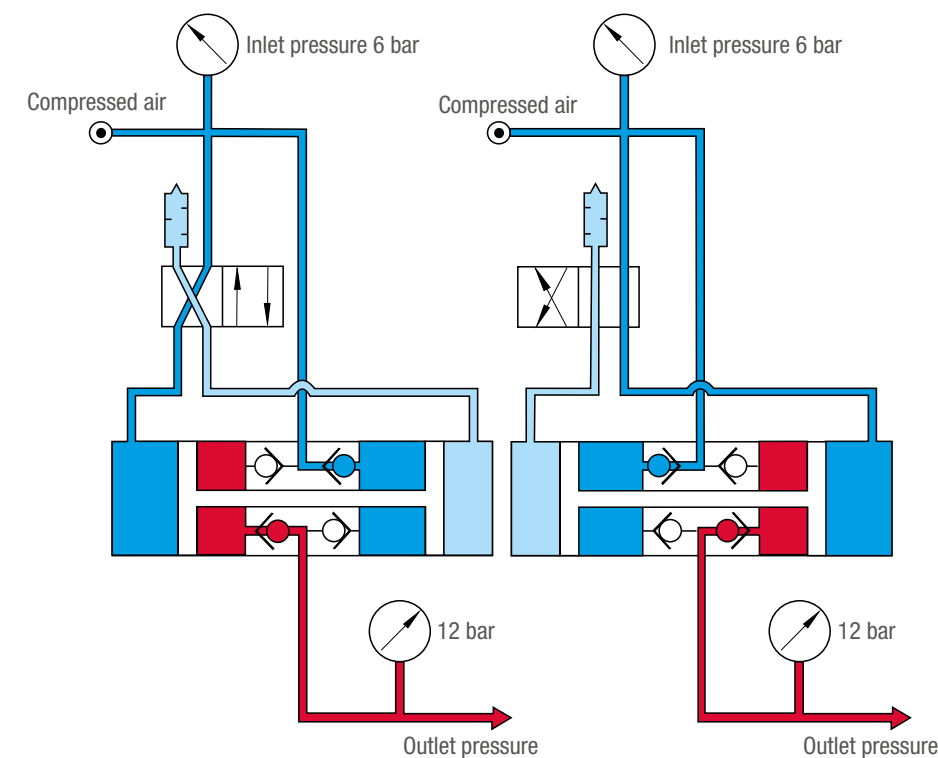

As soon as the drive line is opened, the compressed air is applied to two piston surfaces. Then the gas in one of the two rear piston chambers is compressed.

The pressure ratio results from the two pressurized piston surfaces on the drive side in relation to the one piston surface on the high-pressure side.

## Benefits of Air Amplifiers

- » Selected pressure boosting for individual consumers.
- » Zero energy consumption once final pressure is attained.
- » No electrical installations are required.

# » Product range overview

## Product range and its functions

The Maximator air amplifier series includes devices for low volume flows as well as devices for high volume flows of over 2500 l<sub>n</sub>/min. The products of the PLV series increase the pressure of compressed air or nitrogen up to 100 bar. Depending on the type of application, both single-acting and double-acting devices are available. In the table below, the products of the PLV series are grouped according to their mode of operation. In addition, the respective functional principle is shown schematically:

Single stage, double acting			
Pattern	Type	Pressure ratio i	max. working pressure p <sub>B</sub>
	MPLV 2	1:2	20 bar
	SPLV 2	1:2	20 bar
	GPLV 2	1:2	20 bar
Single stage, single acting (separate high pressure section)			
Pattern	Type	Pressure ratio i	max. working pressure p <sub>B</sub>
	MPLV 2,5	1:2,5	25 bar
	SPLV 3	1:3,2	32 bar
	MPLV 4	1:4	40 bar
	SPLV 10	1:10	100 bar
Single stage, double acting (separate high pressure section)			
Pattern	Type	Pressure ratio i	max. working pressure p <sub>B</sub>
	GPLV 5	1:5	60 bar

## Type coding

**X PLV XX- X**

### Product Series:

» M, S and G

### Pressure ratio:

» from 2 (i = 1:2) up to 10 (i = 1:10)

### Option:

» e.g. : FEC (modification of the spool valve for the drive with dry air or nitrogen) or NPT connections

# Air Amplifier Technology

## » MPLV Series

Maximator MPLV Series air amplifiers are available in single stage, single or double acting design and are suitable for the use in hazardous areas of Zone 1, device group II, device category 2G, explosion group II B. The compact and effective air amplifiers are available in different pressure ratios. They are ideally suited for the selective pressure increase of the existing compressed air pressure up to 40 bar.

### MPLV Series

- » Single or double acting
- » Single stage
- » Working pressure up to 40 bar (580 psi)

- » Suitable for air drive pressures ( $p_i$ ) from 1 to 10 bar (14.5 to 145 psi)

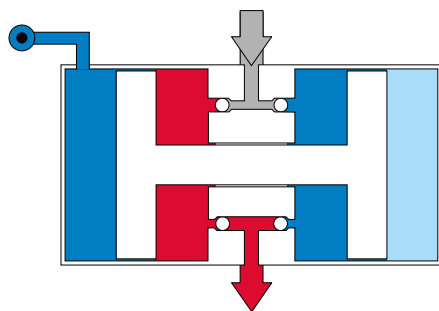

Working principle MPLV 2

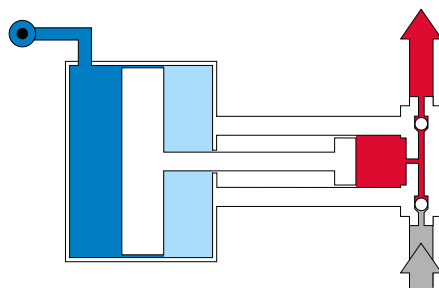

Working principle MPLV 4 / MPLV 2,5

### Options for MPLV Series

- » Special sealing options for high and low temperature applications (-40 up to +60°C)
- » FEC-Option for dry compressed air or nitrogen drive
- » ECO-Option to reduce the air consumption for MPLV 2,5 and MPLV 4
- » Various connections for inlet / outlet (BSP, NPT)

Type	Pressure ratio $i^*$	max. compression ratio $\varepsilon$	max. working pressure $p_B^{**}$		min. gas inlet pressure $p_{Amin}$		max. gas inlet pressure $p_{Amax}$	
			[bar]	[psi]	[bar]	[psi]	[bar]	[psi]
MPLV 2	1:2	1:2	20	290	1	14,5	10	145
MPLV 2,5	1:2,4	1:2,4	25	363	1	14,5	10	145
MPLV 4	1:4	1:4	40	580	2	29	10	145

\* Pressure ratio of air drive piston surface area to output piston surface area

\*\* Maximum permissible static working pressure



MPLV 2

MPLV 4

**Accessories:**

- » Air control unit
- » Pressure switches
- » Cooler
- » Spare part sets
- » Valves, Fittings, Tubing
- » Air Amplifier stations ready for connection according to specification

Further options and accessories on request.

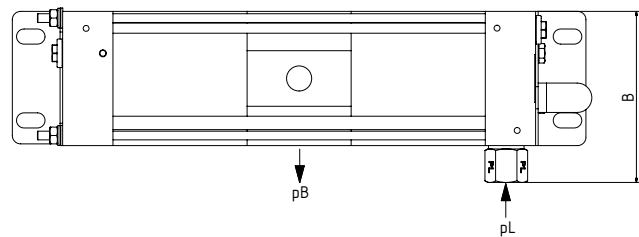
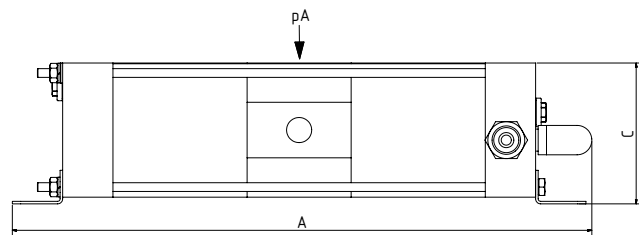

Type	Connections ["]			Dimensions [mm]			max. operating temperatures T [°C]	Weight [kg]
	Drive air	Inlet A	Outlet B	A	B	C		
MPLV 2	G 3/8	G 3/8	G 3/8	346	102	84	60	3,4
MPLV 2,5	G 3/8	G 3/4	G 1/2	238	104	84	60	2,9
MPLV 4	G 3/8	G 3/8	G 1/2	222	104	84	60	2,5

# Air Amplifier Technology

## » MPLV 2-Stations

Maximator MPLV series air amplifier stations are extremely compact systems that are equipped with all required components for an effective pressure increase. The stations include an air control unit consisting of a filter, pressure regulator with pressure gauge and air shut-off valve. Due to the pressure ratio of the air amplifier, the desired working pressure can be preset with the air control unit.



### MPLV 2 Stations

- » Reduced pressure pulsation due to 3L gas tank
- » Any volume peaks that may arise during consumption are compensated by tank volume
- » Working pressure can be optionally set using a pressure regulator at the pressure outlet
- » Working pressure: 20 bar
- » Air Drive pressure: 1 bar - 10 bar
- » Flow capacity: approx. 575 l<sub>v</sub>/min\* (depending on application)
- » Connection
  - » Air Drive p<sub>L</sub>: G 3/8"
  - » Pressure outlet p: G 1/2"
  - » Pressure bleed E: G 1/4"

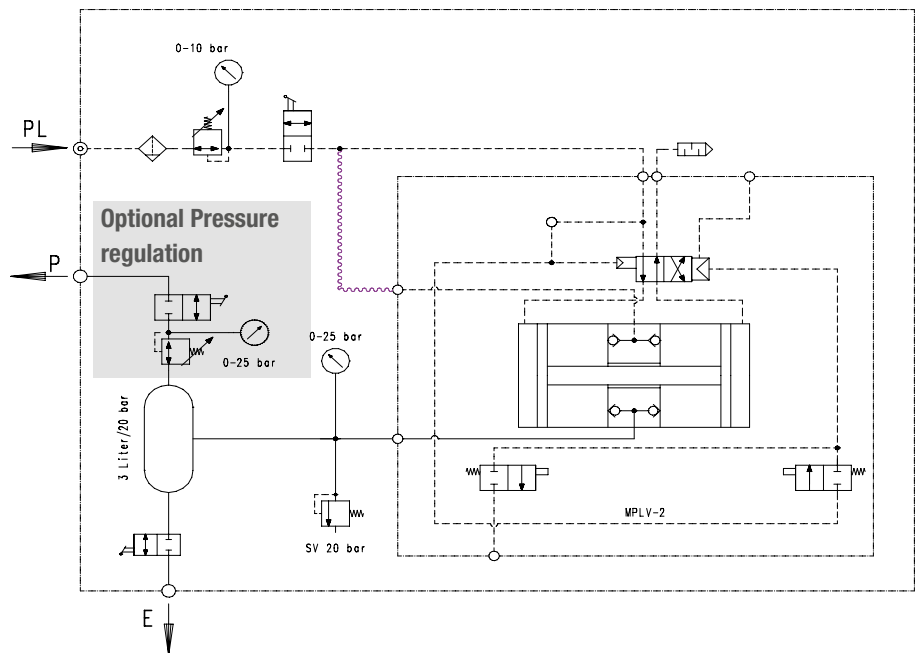

Type	Tank	Pressure regulation	ATEX	Dimensions in mm			Weight kg	Order code
				Width	Depth	Height		
MPLV2/3/20/-	3	-	-	410	235	400	12	3230.2316
MPLV2/3/20/R/-	3	0,5-20 bar	-	410	235	540	13,6	3230.2317
MPLV2/3/20/-/EX	3	-	EX	410	235	400	12	3230.2318
MPLV2/3/20/R/EX	3	0,5-20 bar	EX	410	235	540	13,6	3230.2319

\* With an inlet pressure of 6 bar and an operating pressure of 8 bar, the flow capacity is approx. 575 l<sub>v</sub>/min



# Air Amplifier Technology

## » MPLV 4-Stations

All stations have a tank including a safety device and can optionally be equipped with a pressure regulation. Air amplifier stations that have an EX marking are suitable for use in potentially explosive areas (II 2G Ex h IIB T4 Gb).

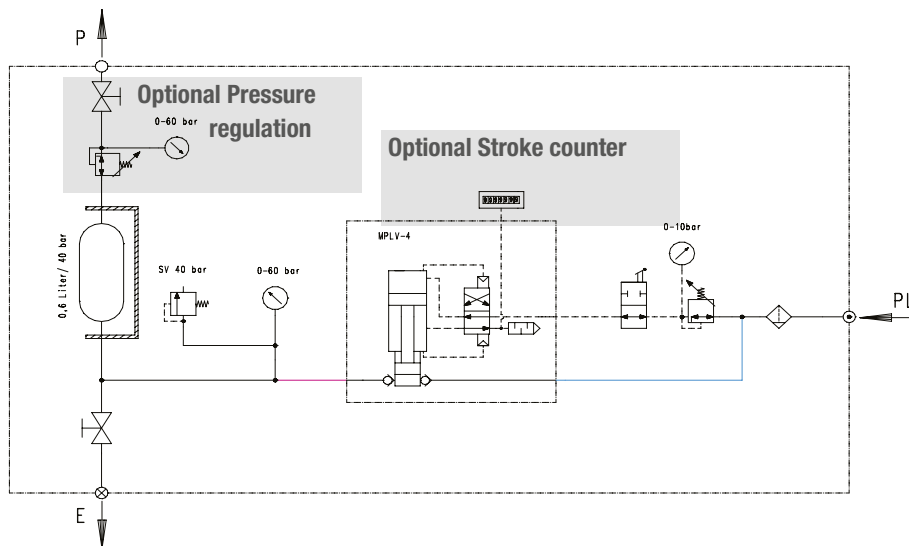
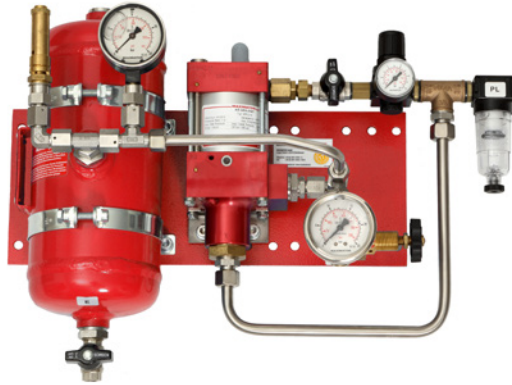

### MPLV 4 Stations

- » Reduced pressure pulsation due to 0,6 L gas tank
- » Any volume peaks that may arise during consumption are compensated by tank volume
- » Working pressure can be optionally set using a pressure regulator at the pressure outlet
  
- » Working pressure: 40 bar  
 Air Drive pressure: 2 bar - 10 bar  
 Flow capacity: approx. 50 l<sub>n</sub>/min\*  
 (depending on application)
  
- » Connection  
 Air Drive p<sub>L</sub>: G 3/8"  
 Pressure outlet p: G 1/4"  
 Pressure bleed E: G 1/4"

Type	Tank	Pressure regulation	Stroke counter	ATEX	Dimensions in mm			Weight kg	Order code
					Width	Depth	Height		
MPLV4L/0,6/40/-/-/-	0,6	-	-	-	450	150	380	6	3230.2302
MPLV4L/0,6/40/R/-/-	0,6	3-40 bar	-	-	450	150	550	8	3230.2303
MPLV4/0,6/40/-/H/EX	0,6	-	yes	EX	450	150	380	6,5	3230.2304
MPLV4/0,6/40/R/H/EX	0,6	3-40 bar	yes	EX	450	150	550	8,5	3230.2305

\* With an inlet pressure of 6 bar and an operating pressure of 8 bar, the flow capacity is approx. 50 l<sub>n</sub>/min

# Air Amplifier Technology

## » SPLV Series

Maximator SPLV Series air amplifiers are available in single stage, single or double acting design and are suitable for the use in hazardous areas of Zone 1, device group II, device category 2G, explosion group II B. The compact and effective air amplifiers are available in different pressure ratios. They are ideally suited for the selective pressure increase of the existing compressed air pressure up to 100 bar.

### SPLV Series

- » Single or double acting
- » Single stage
- » Working pressure up to 100 bar (1450 psi)

- » Suitable for air drive pressures ( $p_d$ ) from 1 to 10 bar (14.5 to 145 psi)

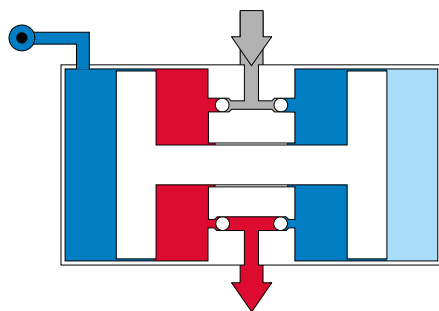

Working principle SPLV 2

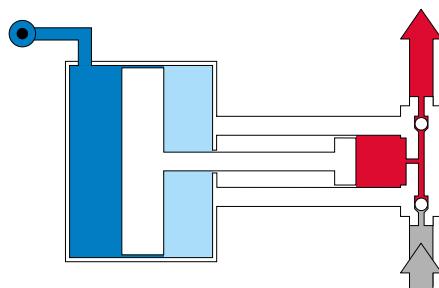

Working principle SPLV 3 / SPLV 10

### Options for SPLV Series

- » Special sealing options for high and low temperature Applications (-40 up to +60°C/+100°C)
- » FEC-Option for dry compressed air or nitrogen drive
- » ECO-Option to reduce the air consumption for SPLV 3 and SPLV 10
- » Various connections for inlet / outlet (BSP, NPT)

Type	Pressure ratio $i^*$	max. compression ratio $\epsilon$	max. working pressure $p_B^{**}$		min. gas inlet pressure $p_{Amin}$		max. gas inlet pressure $p_{Amax}$	
			[bar]	[psi]	[bar]	[psi]	[bar]	[psi]
SPLV 2	1:2	1:2	20	290	1	14,5	10	145
SPLV 3	1:3,2	1:3,2	32	464	1	14,5	32	464
SPLV 10	1:10	1:10	100	1450	1	14,5	100	1450

\* Pressure ratio of air drive piston surface area to output piston surface area

\*\* Maximum permissible static working pressure

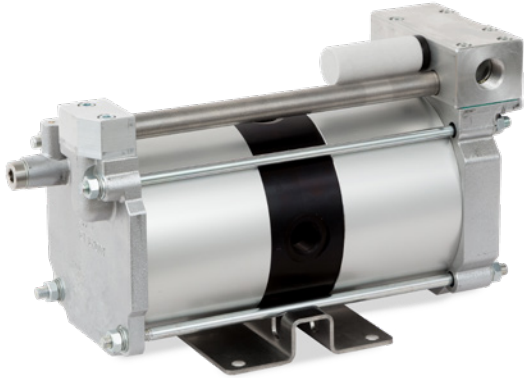

SPLV 2

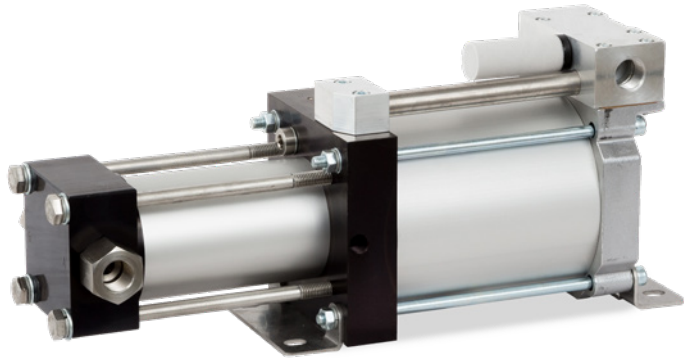

SPLV 3

**Accessories:**

- » Air control unit
- » Pressure switches
- » Cooler
- » Spare part sets
- » Valves, Fittings, Tubing
- » Air Amplifier stations ready for connection according to specification

Further options and accessories on request.

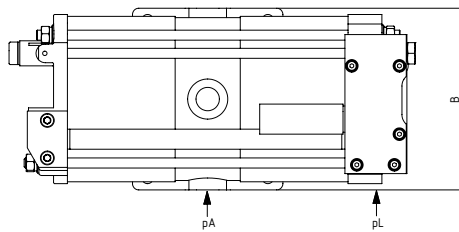
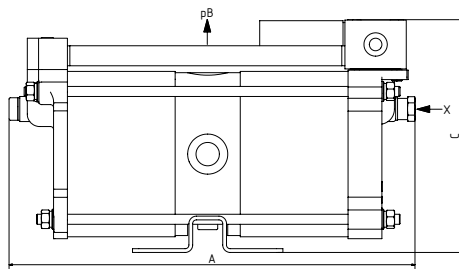

Type	Connections ["]				Dimensions [mm]			max. operating temperatures [°C]	Weight [kg]
	Drive air	Inlet A	Outlet B	Pilot air X	A	B	C		
SPLV 2	G 1/2	G 1/2	G 1/2	G 1/8	324	135	186	60	7,8
SPLV 3	G 1/2	G 1/2	G 1/2	G 1/8	425	168,5	178	60	8,1
SPLV 10	G 1/2	G 1/4	G 1/4	G 1/8	440	158	178	100	9,5

# Air Amplifier Technology

## » SPLV 2-Stations

Maximator SPLV series air amplifier stations are extremely compact systems that are equipped with all required components for an effective pressure increase. The stations include an air control unit consisting of a filter, pressure regulator with pressure gauge and air shut-off valve. Due to the pressure ratio of the air amplifier, the desired working pressure can be preset with the air control unit.

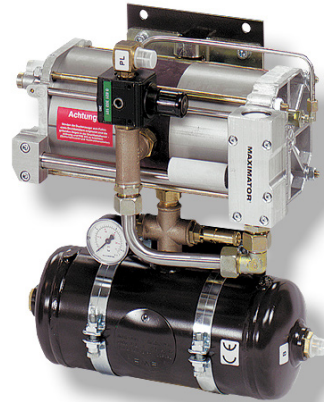

### SPLV 2 Stations

- » Reduced pressure pulsation due to 3L or 20L gas tank
- » Any volume peaks that may arise during consumption are compensated by tank volume
- » Working pressure can be optionally set using a pressure regulator at the pressure outlet
- » Working pressure: 16 bar
- » Air Drive pressure: 1 bar - 8 bar
- » Flow capacity: approx. 960 l<sub>v</sub>/min\*  
(depending on application)
- » Connection
  - » Air Drive p<sub>i</sub>: G 3/8" (3L tank)  
G 1/2" (20L tank)
  - » Pressure outlet p: G 1/2"
  - » Pressure bleed E: G 1/4"

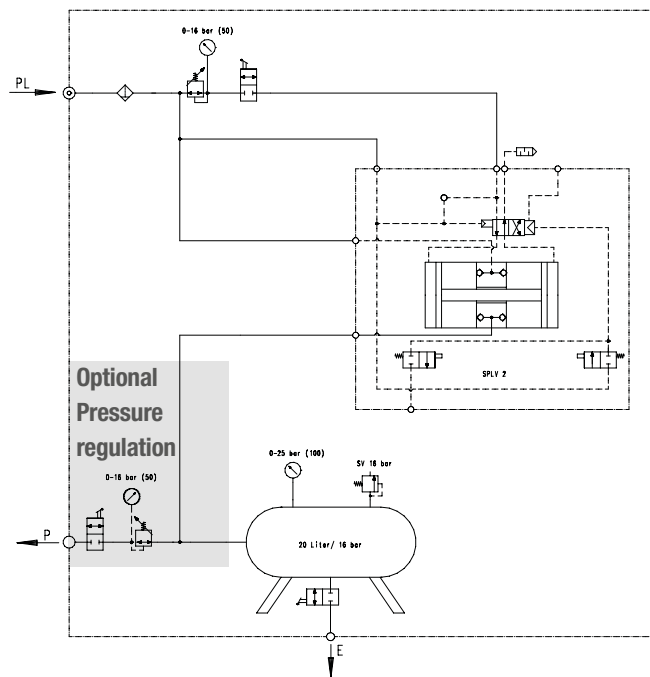

Type	Tank	Pressure regulation	Dimensions in mm			Weight kg	Order code
			Width	Depth	Height		
SPLV2/3/16/-/-	3	-	420	230	350	16	3230.2311
SPLV2/3/16/R/-	3	0,5-16 bar	420	230	410	17	3230.2312
SPLV2/20/16/-/-	20	-	660	360	570	27	3230.0381
SPLV2/20/16/R/-	20	0,5-16 bar	750	360	570	28,5	3230.0673

\* With an inlet pressure of 6 bar and an operating pressure of 8 bar, the flow capacity is approx. 960 l<sub>v</sub>/min

# Air amplifier - technology

## » SPLV 3-Stations

All stations have a tank including a safety device as well as a pressure regulation and can optionally be equipped with an emergency stop. Air amplifier stations that have an EX marking are suitable for use in potentially explosive areas (II 2G Ex h IIB T4 Gb).

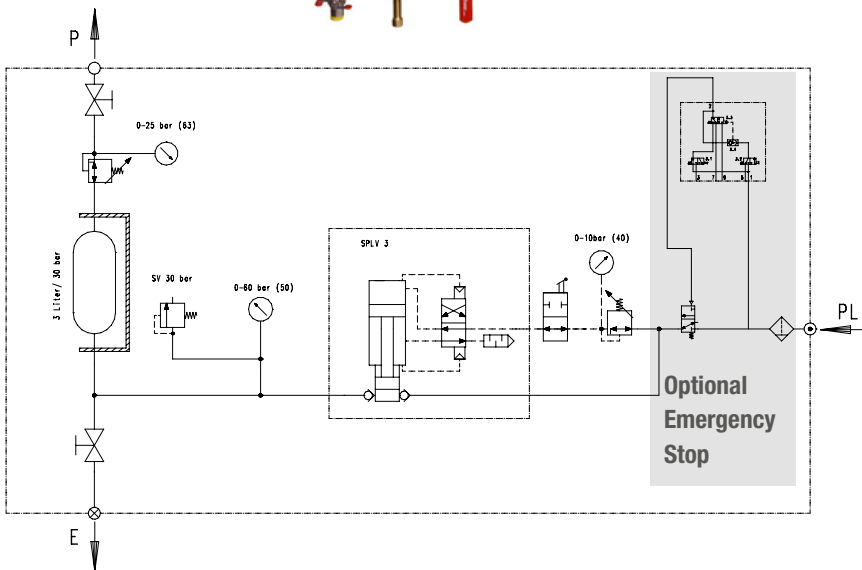

### SPLV 3 Stations

- » Reduced pressure pulsation due to 3L gas tank
- » Any volume peaks that may arise during consumption are compensated by tank volume
- » Working pressure can be optionally set using a pressure regulator at the pressure outlet
- » Working pressure: 25 bar  
Air Drive pressure: 2 bar - 10 bar  
Flow capacity: approx. 200 l<sub>n</sub>/min\*  
(depending on application)
- » Connection  
Air Drive p<sub>L</sub>: G 1/2"  
Pressure outlet p: G 1/2"  
Pressure bleed E: G 1/4"

Type	Tank	Pressure regulation	Emergency stop	ATEX	Dimensions in mm			Weight kg	Order code
					Width	Depth	Height		
SPLV3/3/25/R/-/-	3	2-25 bar	-	-	500	270	660	24,5	3230.1130
SPLV3/3/25/R/NH/-	3	2-25 bar	yes	-	500	270	660	27	3230.1902
SPLV3/3/25/R/-/EX	3	2-25 bar	-	EX	500	270	660	24,5	3230.2778
SPLV3/3/25/R/NH/EX	3	2-25 bar	yes	EX	500	270	660	27	3230.2799

\* With an inlet pressure of 6 bar and an operating pressure of 8 bar, the flow capacity is approx. 200 l<sub>n</sub>/min

# Air Amplifier Technology

## » GPLV Series

Maximator GPLV Series air amplifiers are available in single stage, double acting design and are suitable for the use in hazardous areas of Zone 1, device group II, device category 2G, explosion group II B. The compact and effective air amplifiers are available in different pressure ratios. They are ideally suited for the selective pressure increase of the existing compressed air pressure up to 60 bar.

### GPLV Series

- » Double acting
- » Single stage
- » Working pressure up to 60 bar (870 psi)
- » Suitable for air drive pressures ( $p_d$ ) from 1 to 10 bar (14.5 to 145 psi)

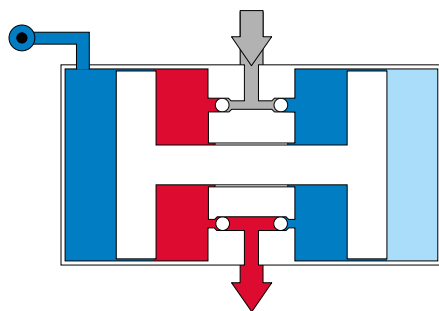

Working principle GPLV 2

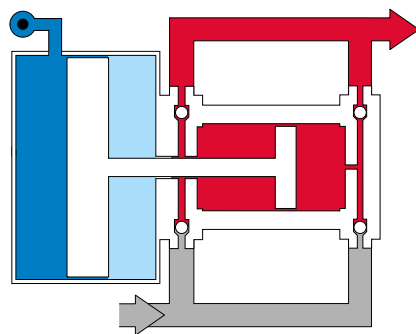

Working principle GPLV 5

### Options for GPLV Series

- » Special sealing options for high and low temperature Applications (-40 up to +60°C)
- » FEC-Option for dry compressed air or nitrogen drive
- » RS-Option: Reduced stroke length reduces the required installation space (only available for GPLV 5)
- » Various connections for inlet / outlet (BSP, NPT)

Type	Pressure ratio $i^*$	max. compression ratio $\epsilon$	max. working pressure $p_B^{**}$		min. gas inlet pressure $p_{Amin}$		max. gas inlet pressure $p_{Amax}$	
			[bar]	[psi]	[bar]	[psi]	[bar]	[psi]
GPLV 2	1:2	1:2	20	290	1	14,5	10	145
GPLV 5	1:5	1:15	60	870	2	29	60	870

\* Pressure ratio of air drive piston surface area to output piston surface area

\*\* Maximum permissible static working pressure



GPLV 2

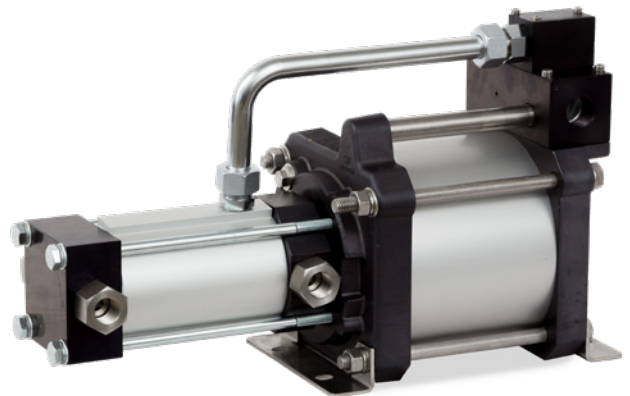

GPLV 5

**Accessories:**

- » Air control unit
- » Pressure switches
- » Cooler
- » Spare part sets
- » Valves, Fittings, Tubing
- » Air Amplifier stations ready for connection according to specification

Further options and accessories on request.

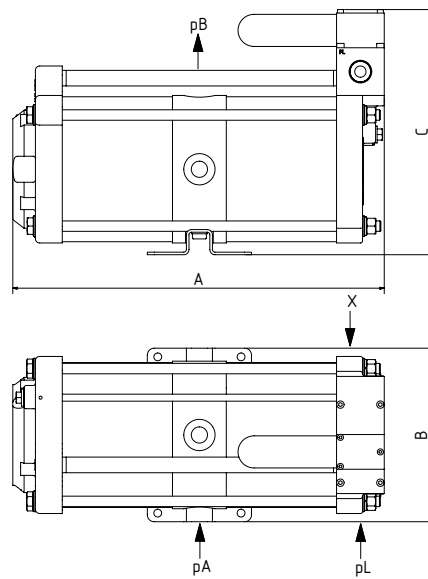

Type	Connections ["]				Dimensions [mm]			max. operating temperatures [°C]	Weight [kg]
	Luft	Einlass A	Auslass B	Steuerluft X	A	B	C		
GPLV 2	G 3/4	G 1/2	G 1/2	G 1/8	428	181	283	60	16,7
GPLV 5	G 3/4	G 1/2	G 1/2	G 1/8	467	181	272	60	14,1

# Air Amplifier Technology

## » GPLV 2-Stations

Maximator GPLV series air amplifier stations are extremely compact systems that are equipped with all required components for an effective pressure increase. The stations include an air control unit consisting of a filter, pressure regulator with pressure gauge and air shut-off valve. Due to the pressure ratio of the air amplifier, the desired working pressure can be preset with the air control unit.



### GPLV 2 Stations

- » Reduced pressure pulsation due to 40L gas tank
- » Any volume peaks that may arise during consumption are compensated by tank volume
- » Working pressure can be optionally set using a pressure regulator at the pressure outlet
- » Working pressure: 16 bar
- » Air Drive pressure: 1 bar - 8 bar
- » Flow capacity: approx. 1200 l<sub>n</sub>/min\* (depending on application)
- » Connection
  - » Air Drive p<sub>i</sub>: G 1/2"
  - » Pressure outlet p: G 1/2"
  - » Pressure bleed E: G 1/4"

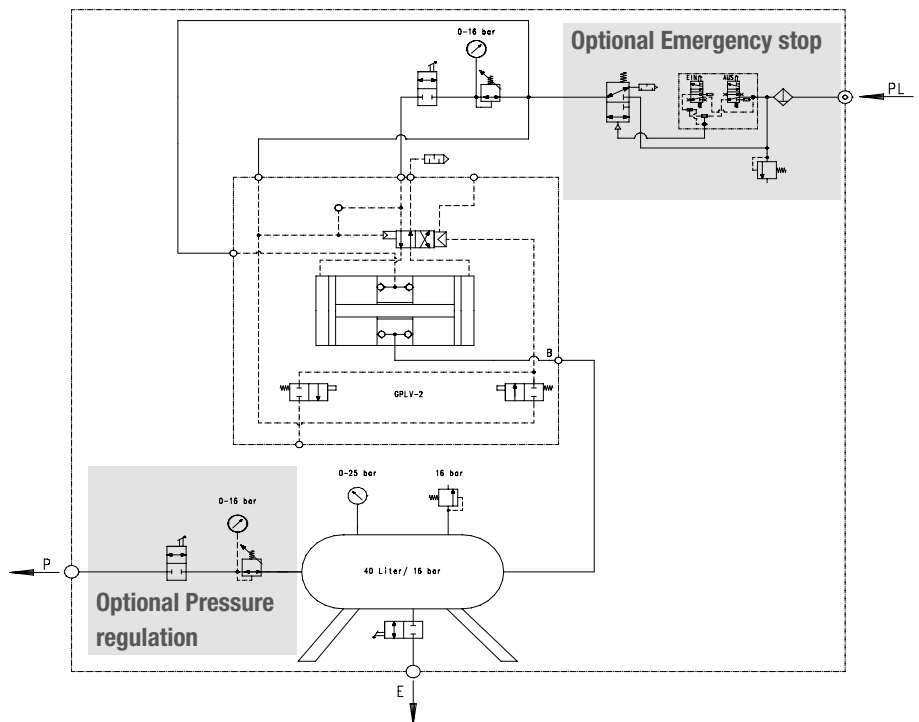

Type	Tank	Pressure regulation	Emergency stop	Dimensions in mm			Weight	Order code
				Width	Depth	Height		
GPLV2/40/16/-	40	-	-	840	380	640	48	3230.0349
GPLV2/40/16/R/-	40	0,5-16 bar	-	900	380	640	49	3230.0737
GPLV2/40/16/-/CE	40	-	yes	970	430	640	54	3230.2253
GPLV2/40/16/R/CE	40	0,5-16 bar	yes	1030	430	640	55	3230.2276

\* With an inlet pressure of 6 bar and an operating pressure of 8 bar, the flow capacity is approx. 1200 l<sub>n</sub>/min



# Air amplifier - technology

## » GPLV 5-Stations

All stations have a tank including a safety device as well as a pressure regulation and can optionally be equipped with an emergency stop. Air amplifier stations that have an EX marking are suitable for use in potentially explosive areas (II 2G Ex h IIB T4 Gb).



### GPLV 5 Stations

- » Reduced pressure pulsation due to 40L gas tank
- » Any volume peaks that may arise during consumption are compensated by tank volume
- » Working pressure can be optionally set using a pressure regulator at the pressure outlet
- » Working pressure: 40 bar  
Air Drive pressure: 2 bar - 10 bar  
Flow capacity: approx. 340 l<sub>n</sub>/min\*  
(depending on application)
- » Connection  
Air Drive p<sub>L</sub>: G 1/2"  
Pressure outlet p: G 1/2"  
Pressure bleed E: G 1/4"

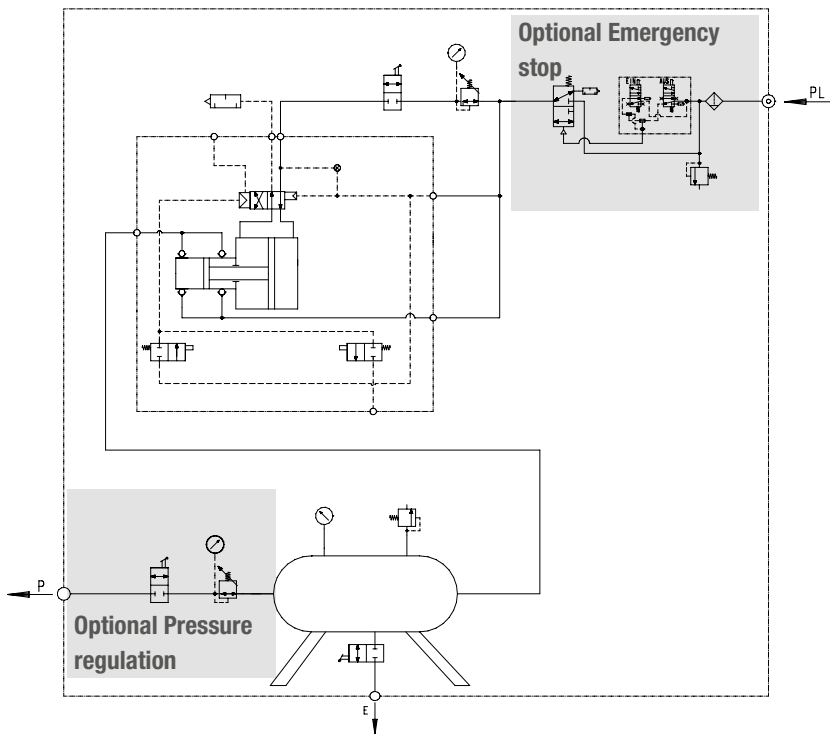

Type	Tank	Pressure regulation	Emergency stop	ATEX	Dimensions in mm			Weight kg	Order code
					Width	Depth	Height		
GPLV5/40/40/-/-/-	40	-	-	-	870	350	670	55	3230.1172
GPLV5/40/40/R/-/-	40	2-40 bar	-	-	990	460	680	64	3230.1238
GPLV5/40/40/R/-/EX	40	2-40 bar	-	EX	990	460	680	65	3230.2388
GPLV5/40/40/-/NH/-	40	-	yes	-	870	350	680	60	3230.2446

\* With an inlet pressure of 6 bar and an operating pressure of 8 bar, the flow capacity is approx. 340 l<sub>n</sub>/min

# Air Amplifier Technology

## » Flow capacity and technical features

### Flow capacity

The flow capacity of air amplifiers mainly depends on the air drive pressure and on the gas inlet pressure. Detailed performance curves can be found in the data sheets for the various air amplifier types at [www.maximator.de](http://www.maximator.de). The flow capacity tables shown here contain rounded values and are used to compare the air amplifier types. Please consult Maximator to determine the expected performance characteristics for a specific application.

Type	$p_L/p_A$ [bar]	$p_B$ [bar]	Q [l <sub>n</sub> /min]	Type	$p_L/p_A$ [bar]	$p_B$ [bar]	Q [l <sub>n</sub> /min]	Type	$p_L/p_A$ [bar]	$p_B$ [bar]	Q [l <sub>n</sub> /min]
MPLV 2	3	5	170	SPLV 2	3	5	285	GPLV 2	3	5	355
	4	5	425		4	5	705		4	5	885
	6	8	575		6	8	960		6	8	1200
	8	15	180		8	15	306		8	15	380
MPLV 2,5	3	5	40	SPLV 3	3	5	155	GPLV 5	3	5	200
	4	8	35		4	8	190		4	8	245
	6	8	105		6	8	280		6	15	340
	8	15	90		8	15	350		8	25	410
MPLV 4	3	5	35	SPLV 10	3	15	20	$p_L$ = Air drive pressure $p_A$ = Gas inlet pressure $p_B$ = Working pressure Q = Flow capacity at working point			
	4	8	45		4	25	25				
	6	15	55		6	40	35				
	8	25	50		8	70	20				

### Overview technical features

Type	Stroke volume [cm <sup>3</sup> ]	max. working pressure $p_B$ [bar]	max. compression ratio $\epsilon$	pressure ratio i	max. operating temperature T [°C]	gas inlet pressure		Connections		Recommended pipe internal diameter		
						min. $p_A$ [bar]	max. $p_A$ [bar]	Inlet A	Outlet B	$p_L$ [mm]	$p_A$ [mm]	$p_B$ [mm]
MPLV 2	274	20	1:2	1:2	60	1	10	G 3/8	G 3/8	9	9	9
MPLV 2,5	54	25	1:2,4	1:2,4	60	1	10	G 3/4	G 1/2	9	9	7
MPLV 4	31	40	1:4	1:4	60	2	10	G 3/8	G 1/2	9	9	7
SPLV 2	620	20	1:2	1:2	60	1	10	G 1/2	G 1/2	12	12	12
SPLV 3	373	32	1:3,2	1:3	60	1	32	G 1/2	G 1/2	12	12	12
SPLV 10	122	100	1:10	1:10	100	1	100	G 1/4	G 1/4	9	9	12
GPLV 2	1900	20	1:2	1:2	60	1	10	G 1/2	G 1/2	12	12	12
GPLV 5	746	60	1:15	1:5	60	2	60	G 1/2	G 1/2	12	12	12

# Additional services

## » Maximator Service and testing services



### Service for your high pressure applications

Our team of more than 50 service professionals at 20 international locations is on hand with their equipment and engineering know-how to support you with your system from the commissioning phase through to operator training courses and maintenance.

We also supply original spare parts for your production equipment. With the focus on transparency, we demonstrate the working

principle of the technologies in product briefings so that you can save time and money right from the start.

Safe and competent handling during operation and maintenance helps to extend the service life of all components and reduce unnecessary downtime, thereby securing your investment in the long term.

Maximator service and maintenance contracts guarantee regular maintenance and servicing of your system.

We make your day-to-day business easier by organising the inspection schedules and planning and executing the continuous maintenance work to ensure that the performance of your machine remains at the highest level.

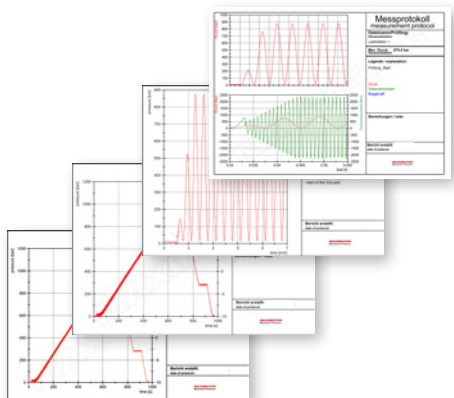
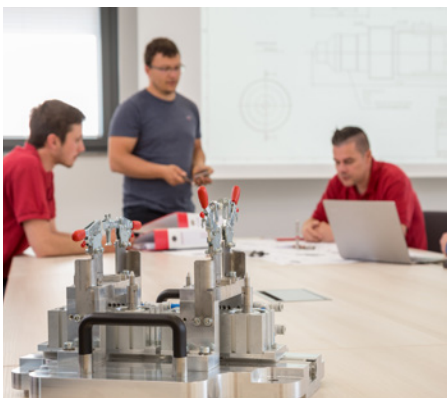

### Testing services

In our test laboratories MAXIFES (Germany), MAXIMATOR Test LLC (USA) and Maximator Customer Center (China) we carry out innovative and cost-efficient services to solve your high-pressure testing tasks.

We carry out static and dynamic pressure tests, burst pressure tests, pressure fatigue and lifecycle tests and autofrettage services quickly and securely.

As a specialist for high-pressure testing it is our pleasure to support you with a wide range of standard or tailored contract testing procedures offered by our state of the art equipped laboratories.

#### An overview of our services:

- Pressure fatigue and life cycle tests (6000 bar/25Hz)
- Pressure, leak and bursting pressure tests (up to 15000 bar)
- Autofrettage (up to 15000 bar)
- Tests with various temperature range (-70°C up to +200°C)

# Additional services

## » Hydraulics and pneumatics



### Running reliable processes

Beside high-pressure gas boosters and air amplifiers, Maximator offers an extensive range of air-driven pumps for operating pressures of up to 7,000 bar. A complete series of valves, fittings and tubings for up to 10,500 bar and an extensive of accessories including pressure regulators, pressure switches, filters, coolers, pressure transducers and pressure gauges makes our portfolio complete.

In addition, we offer a wide spectrum of hydraulic units and booster stations for a very wide range of applications in the fields of general mechanical engineering, automotive engineering, the chemical industry, energy, as well as oil and gas. We also support our customers worldwide with tailor-made solutions.



## High Pressure Pumps

- Pressure generation up to 7000 bar
- Air-driven high pressure pumps which operating according to the principle of a pressure intensifier
- Air-driven operation makes them particularly suitable for use in explosion-protected areas
- No power consumption during long pressure holding periods



## Valves, fittings and tubings

- Engineering and manufacturing exclusively in Germany
- Extensive product range (high-pressure valves, fittings, tubings, check valves, filters, adaptors and more)
- Short delivery times due to flexible in house manufacturing capabilities
- Certificates available for all products (manufacturer's declaration, ATEX and more)



## Hydraulic systems and gas booster stations

- Compact hydraulic units for clamping and testing applications
- Hydraulic systems for on- and offshore applications (Wellhead control panels, testing and supply systems for subsea control modules)
- Injection units and sampling systems
- Flushing stations for extreme environmental conditions
- Booster stations for increasing sealing pressure with gas-sealed mechanical seals
- Gas booster stations for testing and filling tasks
- Filling panels
- Hydraulic units and booster stations in stainless-steel design
- Gas storage and distribution systems
- High pressure accumulators up to 690 bar
- Cylinder bundles to 600 liters

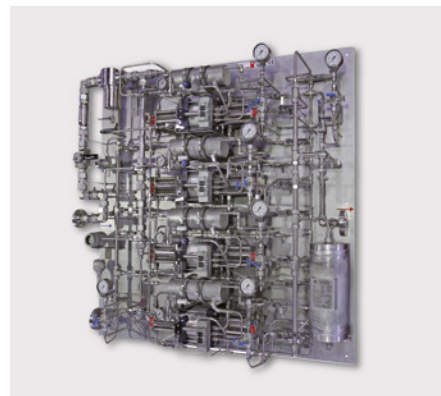

# Additional services

## » High Pressure Technology and Testing Equipment



### Pushing the realms of possibility

Maximator GmbH successfully develops complex systems in high-pressure and testing technology, hydraulics and pneumatics and has been the market leader in these segments for decades. As a specialist in high pressure technology up to 25000 bar, we pursue the aim of optimally supporting each and every customer with our products to develop business potential.

With our top services, we are a partner to well-known companies in the automotive and supply industry, as well as the chemical, plastics, oil and gas industries. We give professional advice, plan projects and supply testing and manufacturing systems. We also develop special solutions precisely customised to the requirements of manufacturers.



## Testing and production systems

- Autofrettage machines (25000 bar)
- Leakage and burst pressure testing technology
- Assembly and functional test systems
- Expansion units
- Pressure pulse test machines (8000 bar)
- High-pressure forming machines
- Testing technology for plastic components
- Testing technology for high-pressure-carrying components in hydrogen mobility



## Gas and water systems for assisted injection moulding

- High-pressure nitrogen supply systems
- Gas regulation and booster stations
- Nitrogen flushing modules
- Water assisted systems
- Gas and water injectors
- Gas dosing stations
- Gas injection control process monitoring
- Hydraulic units for controlling hydraulic actuators, valve pins and retractable gas and water nozzles

## At your side, everywhere

With our international partner companies, experienced experts in high-pressure technology are always ready to assist you. We have compiled detailed contact information for our international partners which you can find on our website at:

**[www.maximator.de/worldwide+distribution](http://www.maximator.de/worldwide+distribution)**.

### **MAXIMATOR GmbH**

Lange Strasse 6, 99734 Nordhausen Germany

Telephone +49 (0) 3631 9533 – 0

Telefax +49 (0) 3631 9533 – 5010

[info@maximator.de](mailto:info@maximator.de)

» Visit our Website:  
» [www.maximator.de](http://www.maximator.de)