

Catalog part number generator for Tube Elbows

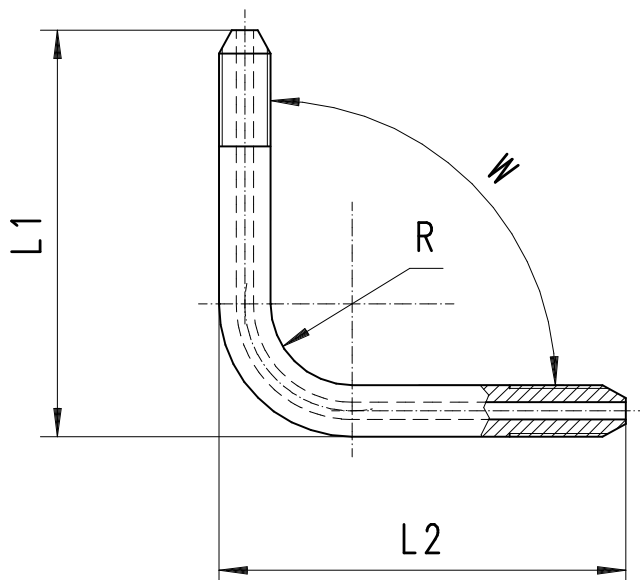

Ordering Information

Typical catalog number: 65TL4H-100-100-90°-25-316

Druckbereich Pressure ksi	Rohrbogen Tube Elbow	Rohrabmessung Dimension	Schenkellänge Leg length L1 = mm	Schenkellänge Leg length L2 = mm	Biegewinkel Angle of bend W = Grad	Biegeradius Bend radius R = mm	Werkstoff Material
65	TL	4H	100	100	90°	25	316
15 21		4M=1/4"					316 304
		6M=3/8"					
		9M=9/16"					
		12M=3/4"					
		16M=1"					
65		4H=1/4"					316 304
		6H=3/8"					
		9H=9/16"					
101 152		4U=1/4"					HP 160
		5U=5/16"					
		6U=3/8"					