

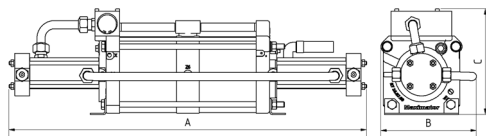

### Technical Data Sheet

### Gas booster DLE 30-2

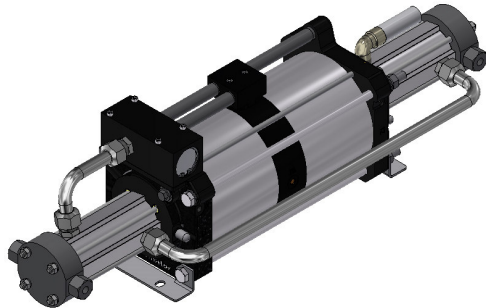

DLE 30-2  
double acting, double air drive head  
single stage

#### Technical Data:

Air drive pressure pL:	1 - 10 bar / 14.5 - 145 psi
Pressure ratio i:	1:60
Compression ratio:	1:20
Minimum suction pressure pA:	20
Maximum suction pressure pA:	600 bar
Maximum outlet pressure pB:	600 bar
Displacement volume/double stroke:	120 cm <sup>3</sup>
Maximum cycles:	100 / min
Stall pressure:	$pB = i * pL + pA$

#### Standard Connections:

Air drive:	3/4" BSP
DLE 30-2 (-GG):	Inlet / Outlet: 1/4" BSP
Maximum operating temperature:	100°C
Net weight:	24.1 kg

Pressure and flow performances, please see enclosed graph.

#### Materials of construction hp section DLE 30-2:

Standard seal package:	PTFE, FKM
Compressor head:	1.4404
HP cylinder:	1.4542
HP piston:	1.4305
Fittings:	1.4404
Balls:	1.4034
Springs:	1.4310

#### Approximate Dimensions:

A:	796 mm
B:	213 mm
C:	233 mm

#### Available Options:

Inert gas service (standard):	DLE 30-2 (-GG)
Oxygen service:	DLE 30-2-GG-S
CO <sub>2</sub> service:	DLE 30-2-GG-C
In-/Outlet: 9/16-18 UNF	DLE 30-2-JU
In-/Outlet: 1/4" NPT	DLE 30-2-NN

#### Available Accessories:

Air control units with filter pressure regulator, control pressure gauge and shut off valve:	DLE 30-2 with C2
To protect the booster against excessive outlet pressures or to limit the outlet pressure, a safety valve can be fitted to the air control unit in the air drive line.	DLE 30-2 with C2 / SV-air (The required outlet pressure has to be indicated.)

**Please consult factory for more information.** All technical and dimensional information subject to change. All General Terms and Conditions of sale, including limitations of our liability, apply to all products and services sold.

