

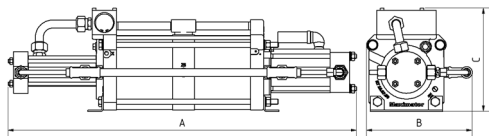

Technical Data Sheet

Gas booster DLE 5-15-2

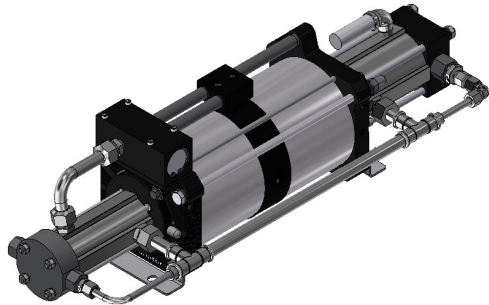

DLE 5-15-2
single acting, double air drive head
two stages

Technical Data:

Air drive pressure pL:	1 - 10 bar / 14,5 - 145 psi
Pressure ratio i:	1:10 / 1:30
Compression ratio:	1:45
Stage pressure ratio:	1:3
Minimum suction pressure pA:	2 bar
Maximum suction pressure pA:	3.2* air drive pressure pL
Maximum outlet pressure pB:	300 bar
Displacement volume/double stroke:	373 cm ³
Maximum cycles:	100 / min
Stall pressure:	pB = 30* pL + 30/10*pA

Standard Connections:

Air drive:	3/4" BSP
DLE 5-15-2 (-GG):	Inlet / Outlet: 1/2" BSP / 1/4" BSP
Maximum operating temperature:	100°C
Net weight:	27.3 kg

Pressure and flow performances, please see enclosed graph.

Materials of construction hp section DLE 5-15-2:

Standard seal package:	PTFE, FKM
Compressor head:	DLE5: 3.1645 DLE15: 1.4404
HP cylinder:	DLE5: 1.4404 DLE15: 1.4542
HP piston:	1.4305
Fittings:	1.4404
Balls:	1.4034
Springs:	1.4310

Approximate Dimensions:

A:	791 mm
B:	240 mm
C:	233 mm

Available Options:

Inert gas service (standard):	DLE 5-15-2 (-GG)
Oxygen service:	DLE 5-15-2-GG-S
CO ₂ service:	DLE 5-15-2-GG-C
In-/Outlet: 1/2" BSP / 4H	DLE 5-15-2-UU
In-/Outlet: 3/8" NPT / 1/4" NPT	DLE 5-15-2-NN

Available Accessories:

Air control units with filter pressure regulator, control pressure gauge and shut off valve:	DLE 15-15-2 with C2
To protect the booster against excessive outlet pressures or to limit the outlet pressure, a safety valve can be fitted to the air control unit in the air drive line:	DLE 15-15-2 with C2 / SV-air (The required outlet pressure has to be indicated.)

Please consult factory for more information. All technical and dimensional information subject to change. All General Terms and Conditions of sale, including limitations of our liability, apply to all products and services sold.

